

YLAA0180SE-YLAA0485SE & YLAA0195HE-YLAA0515HE

ENGINEERING GUIDE

Revision 3

PC181-100 (GB 0809)

AIR COOLED LIQUID CHILLERS WITH SCROLL COMPRESSORS STYLE A (Cooling Capacities: 180 kW to 520 kW)

Tempo



R410A

Table of Contents

TEMPO Features 3	Dimensions - YLAA0180SE & YLAA0210SE 32
Nominal Data. 4	Dimensions - YLAA0195HE 33
Specification.. 5	Dimensions - YLAA0240SE 34
Accessories and Options... .. 6	Dimensions - YLAA0260HE, YLAA0285SE & YLAA0320SE. 35
Refrigerant Flow Diagram.. 8	Dimensions - YLAA0300HE, YLAA0360SE & YLAA0400SE. 36
Component Location Diagrams... .. 9	Dimensions - YLAA0350HE & YLAA0435SE.. 37
Application Data11	Dimensions - YLAA0390HE & YLAA0485SE 38
Location Clearances - SE & SELS Models. 14	Dimensions - YLAA0440HE 39
Location Clearances - HE & HELS Models 14	Dimensions - YLAA0455HE 40
Pipework Arrangement. 15	Dimensions - YLAA0515HE 41
Electrical Connection 16	
Connection Diagram 18	
Evaporator pressure drop graph.. 18	
Operating Limitations - SE Models... .. 19	
Operating Limitations - HE Models 19	
Cooling Capacities - Water Cooling - SE Models. ..20	
Cooling Capacities - Water Cooling - HE Models. ..22	
Cooling Capacities - Water Cooling - SE-LS Models 24	
Cooling Capacities - Water Cooling - HE-LS Models 26	
Fan Power Data..28	
Physical Data - SE Models 29	
Physical Data - HE Models 30	
Electrical Data SE Models. 31	
Electrical Data HE Models. 31	

All data in this document is subject to change without prior notice.

TEMPO Features

YORK TEMPO is a fully packaged air-cooled liquid chiller, with scroll compressors, designed to be located outside on the roof of a building or at ground level

There are two levels of operating efficiency:

- Standard efficiency SE models
- High efficiency HE models

Standard SE and HE chillers have normal speed fans and no compressor enclosure.

Each efficiency level has a selection of acoustic options:

- Two speed fans
- Acoustically lined compressor enclosure
- Acoustically lined compressor enclosure and two speed fans
- Low sound (LS) models with acoustically lined compressor enclosure and fixed low speed fans

Economical operating costs year round

The incorporation of multiple scroll compressors results in high full and part load efficiencies. As each compressor represents a cooling capacity step there is no efficiency reduction when the chiller operates at part load. As the cooling capacity demand falls the available condenser surface increases, in comparison to the load demand, and therefore the part load efficiency exceeds the full load efficiency.

Specifically designed for low sound operation

Most major cities today have rigorous noise control legislation and many applications such as medical, educational, hotels and theatres are extremely noise sensitive. In such situations a chiller must not only meet sound level requirements during the day, when background noise levels often mask chiller sound levels, but also during evenings and at night when legislated levels are more stringent and background levels are diminished.

The TEMPO LS chiller has been specifically designed for low sound operation, to satisfy these varied requirements, by incorporating slow speed fans and arranging all the compressors together in one location and enclosing them in an acoustically treated chamber.

Suits locations where space is restricted

TEMPO has a compact design to suit locations where space is restricted.

Fast and easy installation

TEMPO has a single electrical power connection and optional, factory fitted, water circulating pump(s), water filter and flow switch to provide fast and easy installation.

Buffer tank not normally required

TEMPO requires a minimum water volume to satisfy only one minute of chiller operation at minimum cooling capacity. Therefore on standard air-conditioning systems, such as Fan-Coil etc. a buffer tank is not normally required.

Heat Recovery

An additional dual refrigerant circuit plate heat exchanger provides warm water up to 50°C. Suitable for air driven heating systems and domestic hot water preheat.

Tested for operating reliability

Every TEMPO chiller is fully factory tested before being shipped in order to ensure trouble free installed operation.

Dual refrigeration circuits

TEMPO dual refrigerant circuits and multiple scroll compressors provide system stand-by security.

Plain language 40-character display

TEMPO has a microprocessor controller with a 40-character, plain language, display of temperatures, pressures, operating hours, number of starts and start stop/holiday times. Control functions include accurate leaving liquid temperature, compressor lead/lag, system safety protection and integral circulating pumps.

Efficient low sound fans

TEMPO has aerodynamically designed low sound fans located in separate compartments to prevent air recirculation and to reduce inefficient fan start/stop operation.

All aluminium condenser coils

The incorporation of microchannel aluminium coils provide improved heat transfer, reduced fan power, require less refrigerant and eliminates the possibility of galvanic corrosion, caused by the contact between dissimilar metals. The coil headers, tubes and fins are all aluminium. Coils can be easily pressure washed (100 bar maximum), saving time and sustaining efficiency.

High Efficiency Evaporator

All models have high efficiency evaporators to provide high cooling capacities and low water pressure drops

Nominal Data

YLAA - SE	Fan Speed	YLAA 0180SE	YLAA 0210SE	YLAA 0240SE	YLAA 0285SE	YLAA 0320SE	YLAA 0360SE	YLAA 0400SE	YLAA 0435SE	YLAA 0485SE
Cooling Capacity kW ⁽¹⁾	Normal	179	196	218	276	310	344	386	418	466
Energy Efficiency Ratio (EER) ^(1/1a)		2.84	2.41	2.69	2.71	2.56	2.66	2.55	2.69	2.57
Eurovent Class		C	E	D	C	D	D	D	D	D
ESEER ⁽²⁾		3.95	3.42	3.65	4.09	3.97	3.94	3.79	3.92	3.83
Cooling Capacity kW ⁽¹⁾	Low (LS)	177	193	214	269	301	336	374	408	452
Energy Efficiency Ratio (EER) ^(1/1a)		2.75	2.3	2.63	2.59	2.42	2.54	2.41	2.57	2.43
Eurovent Class		C	E	D	D	E	D	E	D	E
ESEER ⁽²⁾		3.88	3.34	3.67	4.01	3.89	3.96	3.79	3.89	3.80
Sound Pressure at 10 meters dB(A) ⁽³⁾	Normal ⁽⁴⁾	57	58	59	61	62	62	62	64	64
	Normal ⁽⁵⁾	52	53	54	58	57	58	58	59	59
	Low ⁽⁶⁾	48	49	51	54	54	54	54	56	56
	Low ⁽⁷⁾	49	50	52	55	55	55	55	57	57

YLAA - HE	Fan Speed	YLAA 0195HE	YLAA 0260HE	YLAA 0300HE	YLAA 0350HE	YLAA 0390HE	YLAA 0440HE	YLAA 0455HE	YLAA 0515HE
Cooling Capacity kW ⁽¹⁾	Normal	196	253	310	346	386	429	451	521
Energy Efficiency Ratio (EER) ^(1/1a)		3.08	3.03	3.1	3.1	3.03	3.04	3.07	3.06
Eurovent Class		B	B	A	A	B	B	B	B
ESEER ⁽²⁾		4.39	4.72	4.14	3.99	4.15	4.14	4.17	4.33
Cooling Capacity kW ⁽¹⁾	Low (LS)	194	248	304	340	377	421	443	510
Energy Efficiency Ratio (EER) ^(1/1a)		2.98	2.94	3.01	3.03	2.93	2.96	3.01	2.96
Eurovent Class		B	B	B	B	B	B	B	B
ESEER ⁽²⁾		4.26	4.59	4.22	4.01	4.22	4.19	4.22	4.37
Sound Pressure at 10 meters dB(A) ⁽³⁾	Normal ⁽⁴⁾	57	61	61	62	63	63	64	64
	Normal ⁽⁵⁾	52	58	56	57	58	58	59	59
	Low ⁽⁶⁾	48	54	53	54	55	55	56	56
	Low ⁽⁷⁾	49	55	54	55	56	56	57	57

(1) At 7°C leaving chilled water and 35°C ambient

(1a) EER = Cooling Capacity / Total kW Input from compressors and fans

(2) ESEER is European Seasonal Energy Efficiency Ratio. $ESEER = 0.03A + 0.33B + 0.41C + 0.23D$

A = EER at 100% capacity at 35°C ambient. B = EER at 75% capacity at 30°C ambient.

C = EER at 50% capacity at 25°C ambient. D = EER at 25% capacity at 20°C ambient.

(3) Sound Pressure in free field conditions

(4) Fans operating at normal speed without compressor enclosure at 7°C leaving chilled water and 35°C ambient.

(5) Fans operating at normal speed with compressor enclosure at 7°C leaving chilled water and 35°C ambient.

(6) Optional dual speed fans operating at low speed with compressor enclosure at 7°C leaving chilled water and 25°C ambient.

(7) LS Model: fixed low speed fans with compressor enclosure at 7°C leaving chilled water and 35°C ambient

Data based on 5°C chilled liquid temperature difference and 0.018m²C/kW fouling factor

Specification

YLAA air-cooled chillers are completely factory assembled with all interconnecting refrigerant piping and wiring ready for field installation. The unit is pressure tested, evacuated, and fully factory charged with refrigerant R410A and oil in each of the independent refrigerant circuits. After assembly, an operational test is performed with water flowing through the evaporator to ensure that each refrigerant circuit operates correctly.

The unit structure is manufactured from heavy-gauge, galvanised steel coated with baked-on powder paint (Champagne (RAL 7006, Munsell No. 9.8YR4.36/1.2)).

YLAA chillers are designed and manufactured within an EN ISO 9001 accredited organisation and in conformity with the following European Directives:

- Machinery Directive (98/37/EC)
- Low Voltage Directive (2006/95/EC)
- EMC Directive (2004/108/EC)
- Pressure Equipment Directive (97/23/EC)

Compressors

The unit has suction-cooled, hermetic scroll compressors. High efficiency is achieved through a controlled orbit and the use of advanced scroll geometry. The compressors incorporate a compliant scroll design in both the axial and radial directions. All rotating parts are statically and dynamically balanced. The compressor motors have integral protection against overloads that will automatically reset. Starting is direct on line, and soft start is available as an option.

The compressors are switched On and Off by the unit microprocessor to provide capacity control. Each compressor is fitted with a crankcase strap heater. All compressors are mounted on isolator pads to reduce transmission of vibration to the rest of the unit.

The motor terminal boxes have IP 54 weather protection.

Refrigerant Circuits

Two independent refrigerant circuits are provided on each unit. Each circuit uses copper refrigerant pipe formed on computer controlled bending machines to reduce the number of brazed joints resulting in a reliable and leak resistant system.

Liquid line components include: a service valve with charging port, a high absorption removable core filter-drier, a solenoid valve, a sight glass with moisture indicator and a thermal expansion valve. Liquid lines between the expansion valve and the cooler are insulated with flexible, closed-cell foam.

Suction line components include: a pressure relief valve, a pressure transducer and a service valve. Suction lines are insulated with flexible, closed-cell foam.

Discharge lines include service and isolation ball valves, a high-pressure cutout switch, a pressure transducer and a pressure relief valve.

Evaporator

The evaporator on models YLAA0180SE, YLAA0210SE and YLAA0240SE is a stainless steel plate type heat exchanger with a design working pressure of 10 barg on the water side. All other models have a shell and tubes type evaporator.

The 2-pass dual circuit shell and tube type direct expansion (DX) evaporator has refrigerant in the tubes and chilled liquid flowing through the baffled shell. The waterside (shell) design working pressure of the cooler is 10.3 bar g. The refrigerant side (tubes) design working pressure is 27.6 bar g. The refrigerant side is protected by pressure relief valve(s).

Water Connection to the evaporator is via victaulic grooved connections. Victaulic flange connections are available as an option.

Air Cooled Condensers

Each condenser coil is a single piece all aluminium construction including headers, tubes and fins to avoid galvanic corrosion due to dissimilar metals. Coils and headers are brazed as one piece. Integral subcooling is included. The design working pressure is 43 bar.

The condenser fans have metal 'sickle' blades integrated into the rotor of an external rotor motor. They are designed for maximum efficiency and statically and dynamically balanced for vibration free operation. They are directly driven by independent motors, and positioned for vertical air discharge. The fan guards are constructed from heavy-gauge, corrosion resistant, coated steel.

The IP 54 fan motors are the totally enclosed air-over type with permanently lubricated double-sealed ball bearings.

Power and Controls Panels

All power and controls are contained in an IP 55 cabinet with hinged, latched and gasket sealed outer doors.

The power panel includes:

- A factory mounted non-fused disconnect switch with external, lockable handle to enable connection of the unit power supply. The disconnect switch can be used to isolate the power for servicing.
- Factory mounted compressor contactors and compressor fuses provide short circuit protection. Overload protection for each compressor is provided by inherent motor winding temperature sensing and a trip module.
- Factory mounted fan contactors and fuses provide short circuit protection. Overload protection for each fan is provided by a inherent motor winding temperature device.
- Factory mounted control transformer to convert the unit supply voltage to 110 V - 1 Ø - 50 Hz for the control system.
- Control supply fuses and connections for a remote emergency stop device.

The control panel includes:

- A Liquid Crystal Display (two display lines of twenty characters per line) with Light Emitting Diode backlighting for easy viewing
- A Colour coded 12-button keypad
- Customer terminal blocks for control inputs and liquid flow switch.

Microprocessor Controls

The microprocessor control includes:

- Automatic control of compressor start/stop, anticoincidence and anti-recycle timers, automatic pumpdown on shutdown, evaporator pump and unit alarm contacts. Automatic reset to normal chiller operation after power failure.
- Remote water temperature setpoint reset via a pulse width modulated (PWM) input signal or up to two steps of demand (load) limiting
- Software is loaded into the microprocessor controller via a SD card, with programmed setpoints retained in a lithium battery backed real time clock (RTC) memory.
- Forty character liquid crystal display, with description available in five languages (English, French, German, Spanish or Italian)

Programmable setpoints:

- Chilled liquid temperature setpoint and range
- Remote reset temperature range
- Set daily schedule/holiday for start/stop
- Manual override for servicing
- Low and High ambients cutouts
- Low liquid temperature cutout
- Low suction pressure cutout
- High discharge pressure cutout
- Anti-recycle timer (compressor start cycle time)
- Anti-coincident timer (delay compressor starts)

Displayed Data:

- Return and leaving liquid temperature
- Low leaving liquid temperature cutout setting
- Low ambient temperature cutout setting
- Ambient air temperature
- Metric or Imperial data
- Discharge and suction pressure cutout settings
- System discharge and suction pressures
- Anti-recycle timer status for each compressor
- Anti-coincident system start timer condition
- Compressor run status
- No cooling load condition
- Day, date and time
- Daily start/stop times
- Holiday status
- Automatic or manual system lead/lag control
- Lead system definition

- Compressor starts & operating hours (each compressor)
- Status of evaporator heater and fan operation
- Run permissive status
- Number of compressors running
- Liquid solenoid valve status
- Load & unload timer status
- Water pump status

System Safeties:

- Cause individual compressors to perform auto shut down and require manual reset in the event of 3 trips in a 90-minute time period
- High discharge pressure
- Low suction pressure
- High-pressure switches
- Motor protector

Unit Safeties:

- They are automatic reset and cause compressor to shut down
- Low leaving chilled liquid temperature
- Under voltage
- Loss of liquid flow (through flow switch)

Alarm Contacts:

- Low leaving chilled liquid temperature
- Low voltage
- Low battery
- High discharge pressure (per system)
- Low suction pressure (per system)

Accessories and Options

Power Factor Correction

Factory mounted passive (static) power factor correction capacitors to correct unit compressor power factors to a target of 0.9 (depending on operating conditions). Option not available on compressors fitted with soft start option.

Soft Starters

Factory mounted soft starters reduce the inrush current to the last compressor on each refrigerant circuit. They are preset so that no field adjustment is required. . This option is not available for units operating in ambients greater than 35°C.

Language LCD and Keypad

English, French, German, Italian and Spanish unit LCD read out and keypad available. Standard Language is English.

Multi-Chiller Sequencer

The multi-chiller sequencer has been designed to manage up to four chillers, piped in parallel, from a common chilled water sensor. The sequencer is factory mounted in an IP55 panel with viewing window, lockable door and an electrical isolator. To be field fitted and wired to power supply and chillers.

Heat Recovery

Stainless steel, dual refrigerant circuit, plate heat exchanger with victaulic water connections.

Hydrokit

Factory fitted Hydrokit suitable for water glycol systems with up to 35% glycol at leaving liquid temperatures down to -7°C. The kit is available in single or dual motor configuration (dual as standby duty only), with totally enclosed permanently lubricated pump motors.

The Hydrokit option is provided with a balancing valve, flow switch, pressure ports (gauges to be supplied by others), suction guide, strainer, bleed and drain valves and frost protection.

The pumps and flow switch are factory wired to the chiller control system to provide auto pump starting and running.

Victaulic Flange Kit

Victaulic PN10 flange joint kit supplied loose for field installation. Includes flanges and companion flanges and all necessary nuts, bolts and gaskets.

38 mm Evaporator Insulation

Double thickness insulation provided for enhanced efficiency, and low temperature applications.

Flow Switch

Vapour Proof, paddle-type with 1" NPT connection for upright mounting in horizontal pipe. This flow switch or its equivalent must be supplied with each unit to protect the evaporator from loss of liquid flow (Field Mounted)

Dual Pressure Relief Valves

Two pressure relief valves mounted on a 3-way valve in parallel of which one is operational and the other one assists during maintenance.

Low Sound (LS) Unit

Includes low speed fans and compressor acoustic enclosures (factory fit).

Compressor Acoustic Enclosure

Factory fit acoustically lined, painted galvanised steel, enclosure with removable panels.

Dual speed fans

Fans operate either in high mode (920 RPM) or in low mode (670 RPM). Fan speed reduces automatically from high to low mode as head pressure falls, or at programmed times within the control software.

High Pressure Fans

Fans and motors suitable for high external static conditions up to 120 Pa.

High Ambient Kit

Double skinned control panel, to offset solar heat, should be selected for all units operating in ambients greater than 46°C.

Low Ambient Kit

This accessory includes fan speed control, on one fan per refrigerant circuit, to permit chiller operation below -1°C and down to -18°C ambient temperature.

Condenser Coil Louvred Panels

Louvred panels mounted over the condenser coils.

Condenser Coil Louvred Panels and Unit Wire Guards

Louvred panels mounted over the condenser coils, and welded wire mesh guards mounted around the bottom of the unit.

Unit Wire Enclosure

Welded wire mesh guards over condenser coils and around the bottom of the unit.

Aesthetic Vee Panels

Panels covering the pipework on the side of each condenser module.

Coil End Hail Guard

Louvred panel attached to exposed coil end.

Neoprene Pads Isolators

Recommended for normal installations (Field mounted)

25 mm Spring Isolators

Level adjustable, spring and cage type isolators for mounting under the unit base rails (Field mounted)

Lifting Lug Kit

One set of ISO MK5 camlocs to enable safe and easy unit handling.

Refrigerant Flow Diagram

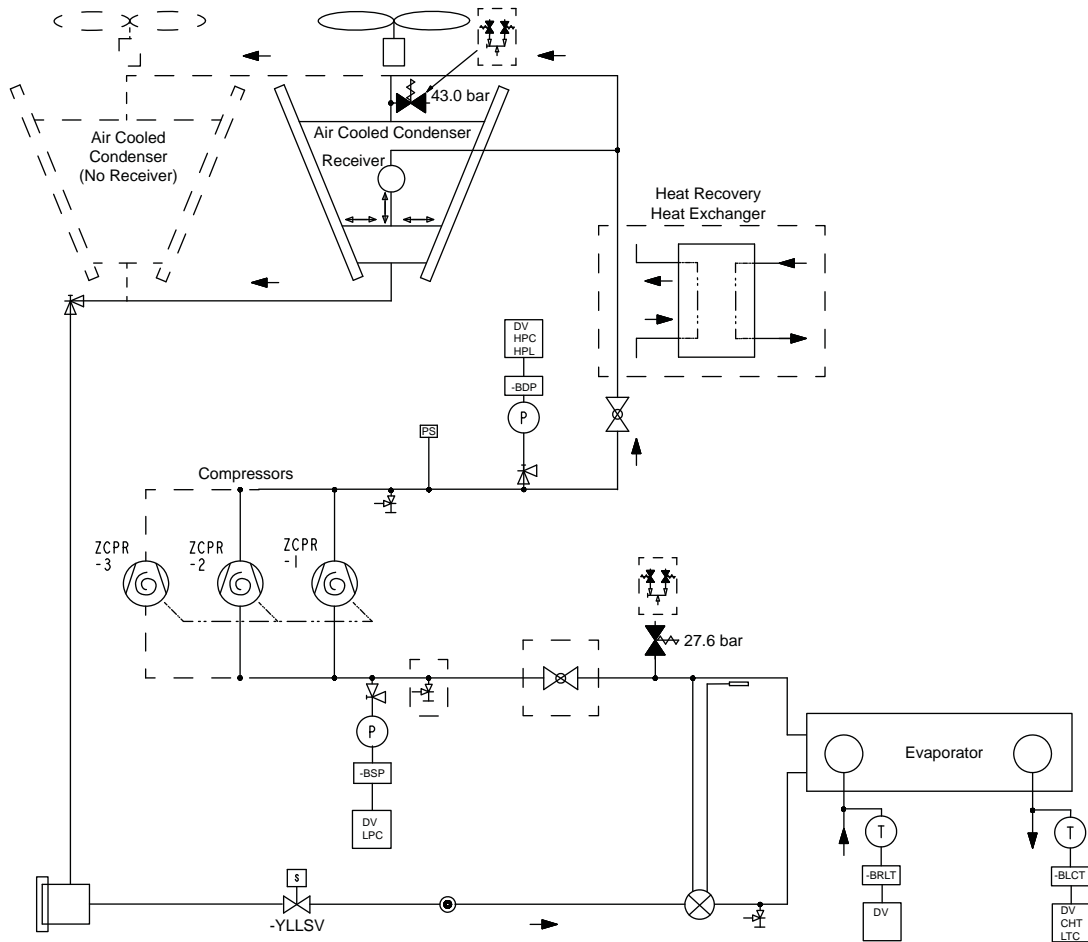

Components:

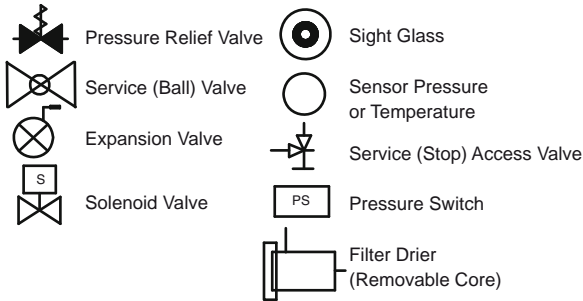

Control Functions:

CHT - Chilled Liquid Temperature
 HPC - High Pressure Cutout
 LPC - Low Pressure Cutout
 HPL - High Pressure Load Limiting
 HTC - High Temperature Cutout
 LTC - Low Temperature Cutout
 DV - Display Value

Pressure Transducers:

-BDP Discharge Pressure
 -BSP Suction Pressure

Temperature Sensors:

-BLCT Leaving Chilled Temperature
 -BRLT Return Liquid Temperature

Solenoid Valves:

-YLLSV Liquid Line Solenoid Valve

Low pressure liquid refrigerant enters the evaporator and is evaporated and superheated by the heat energy absorbed from the chilled liquid. Low pressure vapour enters the compressor where pressure and superheat are increased. The high pressure vapour is fed to the air cooled condenser coil and fans where heat is removed. The fully condensed and subcooled liquid passes through the expansion valve where pressure is reduced and further cooling takes place before returning to the evaporator.

Component Location Diagrams

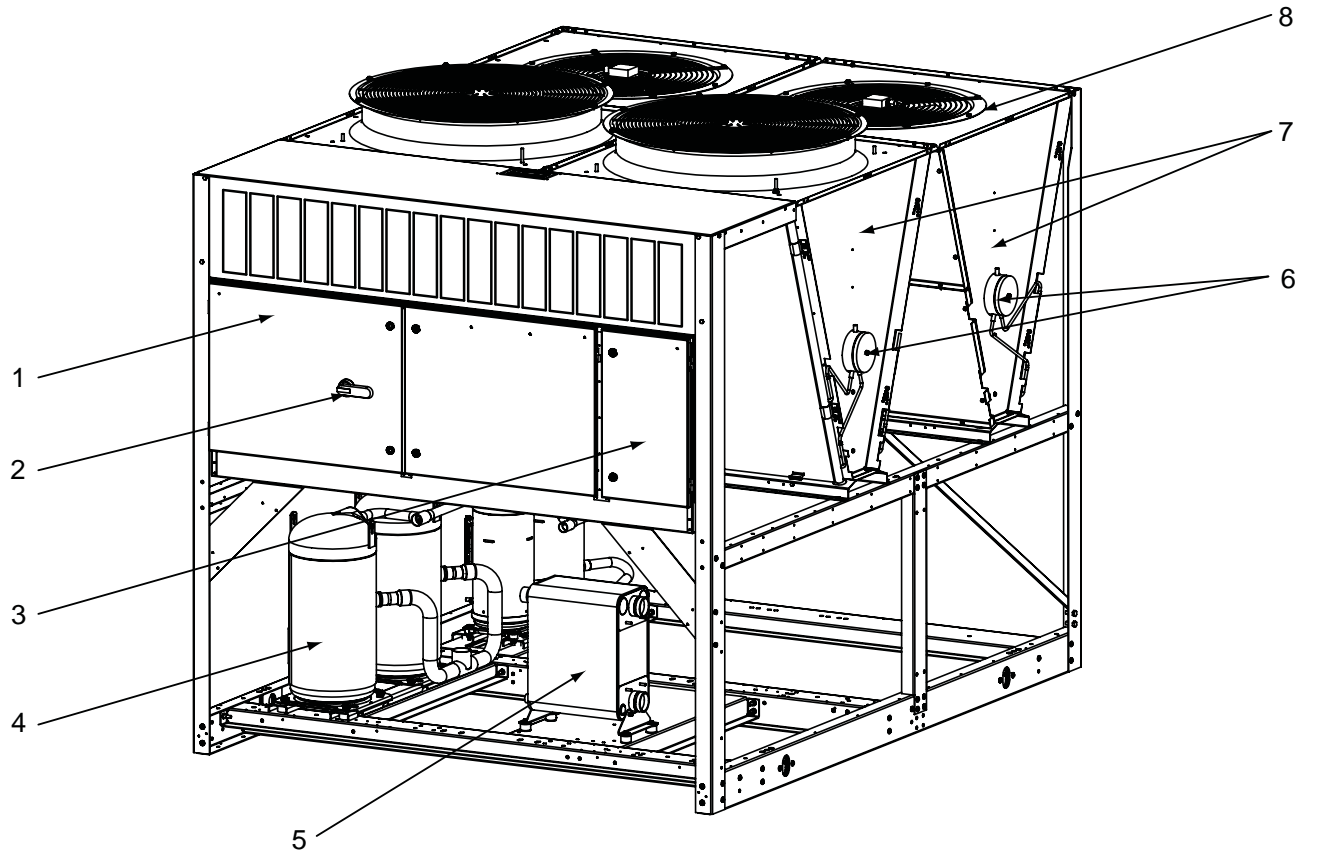
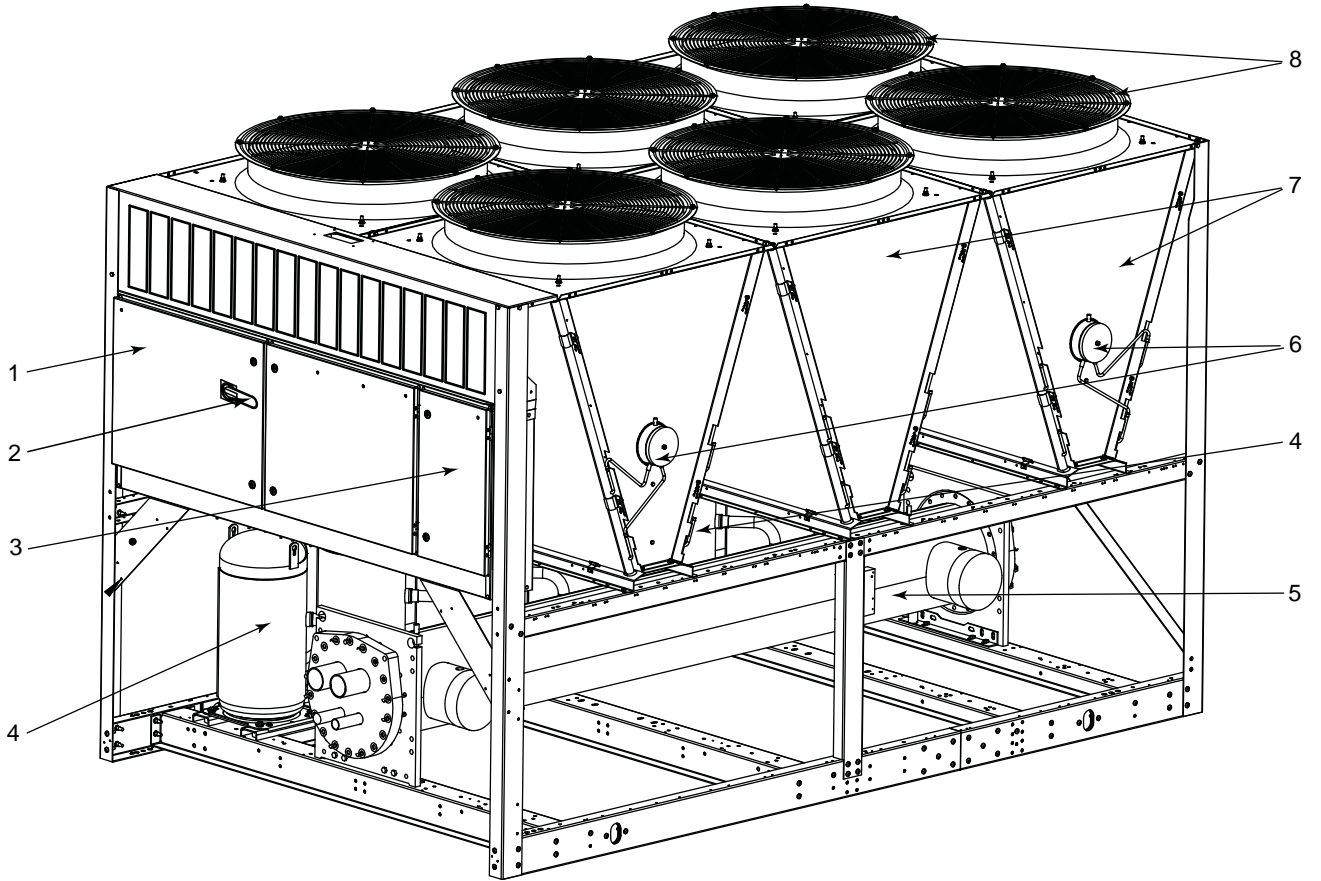

- | | |
|-------------------------------|--------------|
| 1 Power Panel | 5 Evaporator |
| 2 Non-Fused Disconnect Switch | 6 Receiver |
| 3 Control Panel | 7 Condenser |
| 4 Compressor | 8 Fans |

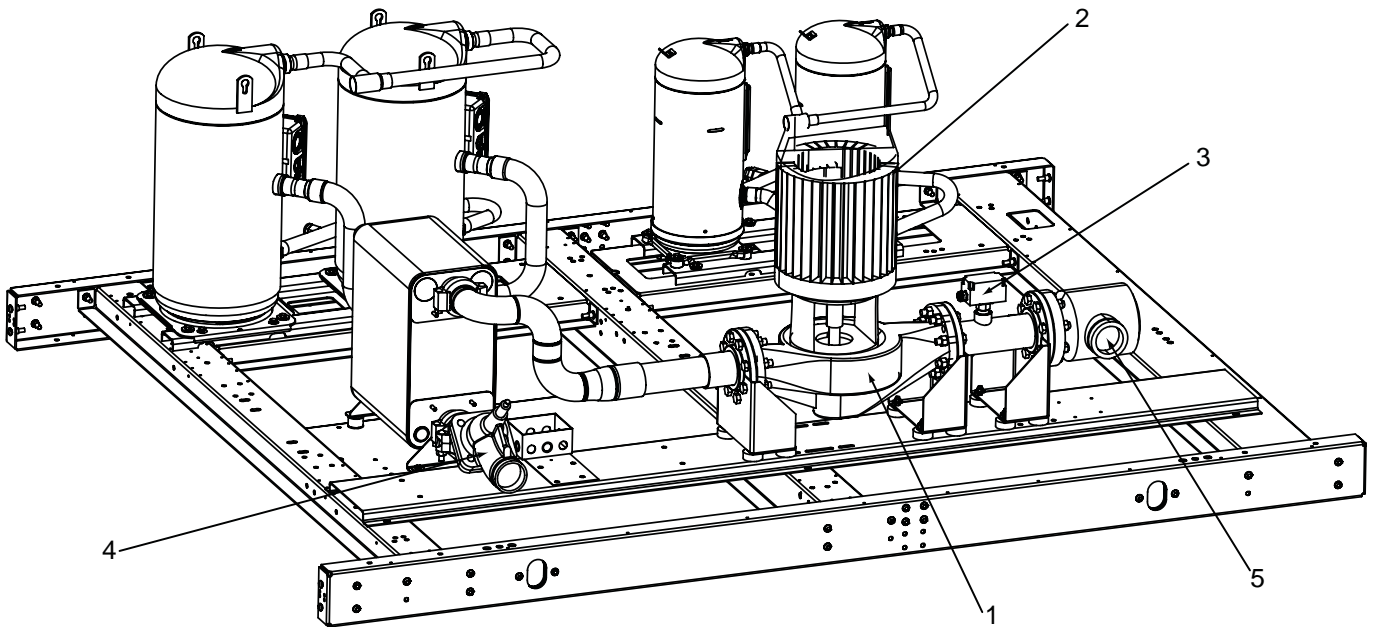
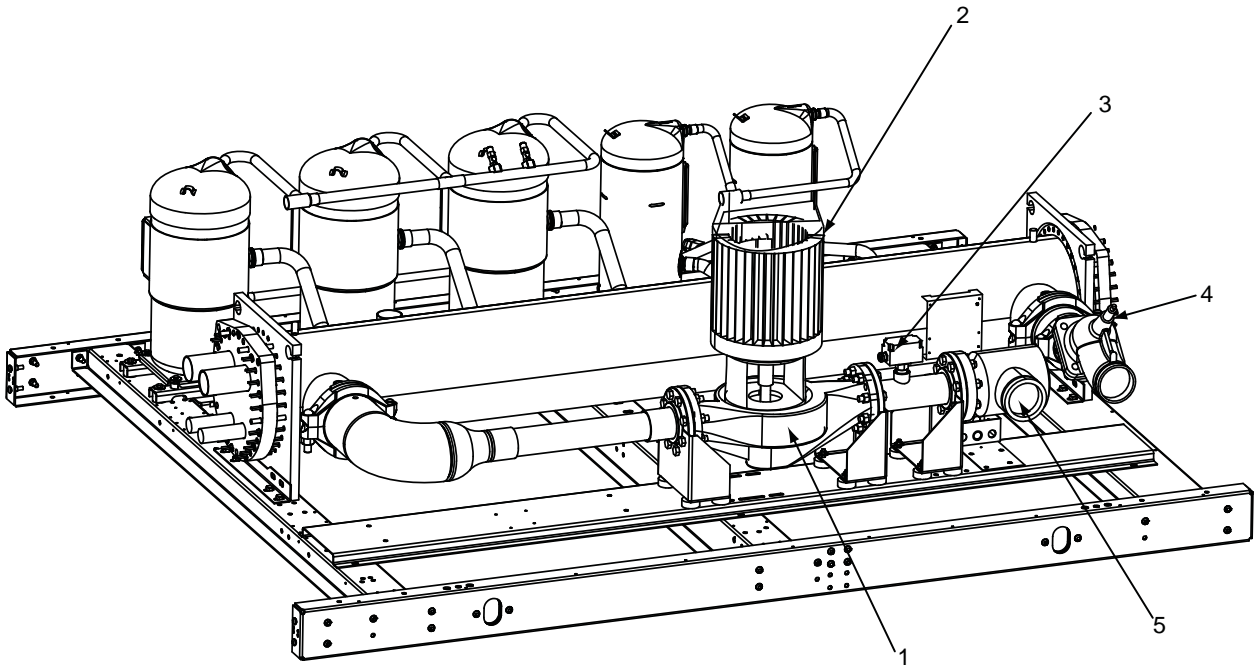

- | | |
|-------------------------------|--|
| 1 Pump Body (Single or Dual) | 4 Balancing valve with flow check and shut-off functions |
| 2 Pump Motor (Single or Dual) | 5 Suction Guide with integrated strainer |
| 3 Flow Switch | |

Application Data

Location Requirements

To achieve optimum performance and trouble-free service, it is essential that the proposed installation site meet with the location and space requirements for the model being installed.

The clearances recommended are nominal for the safe and efficient operation and maintenance of the unit and power and control panels. Local Health and safety regulations, or practical considerations for service replacement of large components, may require larger clearances than those given in this manual.

Outdoor installations

The units can be installed at ground level on a suitable at level foundation easily capable of supporting the weight of the unit, or on a suitable rooftop location. In both cases an adequate supply of air is required. Avoid locations where the sound output and air discharge from the unit may be objectionable.

The location should be selected for minimum sun exposure and away from boiler flues and other sources of airborne chemicals that could attack the condenser coils and steel parts of the unit.

If located in an area accessible to unauthorized persons, steps must be taken to prevent access to the unit by means of a protective fence. This will help to prevent the possibility of vandalism, accidental damage, or possible harm caused by unauthorized removal of protective guards or opening panels to expose rotating or high voltage components.

For ground level locations, the unit must be installed on a suitable flat and level concrete base that extends to fully support the two side channels of the unit base frame. A one-piece concrete slab, with footings extending below the frost line is recommended. To avoid noise and vibration transmission, the unit should not be secured to the building foundation.

On rooftop locations, choose a place with adequate structural strength to safely support the entire operating weight of the unit and service personnel. The unit can be mounted on a concrete slab, similar to ground floor locations, or on steel channels of suitable strength. The channels should be spaced with the same centres as the unit side and front base rails. This will allow vibration isolators to be fitted if required. Isolators are recommended for rooftop locations. Any ductwork or attenuators fitted to the unit must not have a total static pressure resistance, at full unit air-flow, exceeding the capability of the fans installed in the unit.

Indoor installations

The unit can be installed in an enclosed plant room, provided the floor is level and of suitable strength to support the full operating weight of the unit. It is essential that there is adequate clearance for air flow to the unit. The discharge air from the top of the unit must be ducted away to prevent re-circulation of air within the plant room. If common ducts are used for fans, non-return dampers must be fitted to the outlet from each fan.

The discharge ducting must be properly sized with a total static pressure loss, together with any intake static pressure loss, less than the available static pressure capability for the type of fan fitted.

The discharge air duct usually rejects outside the building through a louvre. The outlet must be positioned to prevent the air being drawn directly back into the air intake for the condenser coils, as such re-circulation will affect unit performance.

Operating in low ambient conditions

If low cooling capacities are required, at lower ambient conditions (below -1°C), the refrigerant pressure will fall. To prevent operational problems the low ambient kit option should be used.

For efficient head pressure control in ambients below -1°C , where unusually high wind gusts are expected, it is recommended that, if the customer has not provided a wind break, the optional condenser louvred enclosure panels are included.

High static fan ductwork connection

The following ductwork recommendations are intended to ensure satisfactory operation of the unit, when optional high static fans are used. Failure to follow these recommendations could cause damage to the unit, or loss of performance, and may invalidate the warranty. When ducting is to be fitted to the fan discharge it is recommended that the duct should be the same cross sectional area as the fan outlet and straight for at least 1 meter to obtain static regain from the fan.

Ductwork should be suspended with flexible hangers to prevent noise and vibration being transmitted to the structure. A flexible joint is also recommended between the duct attached to the fan and the next section for the same reason. Flexible connectors should not be allowed to concertina.

The unit is not designed to take structural loading. No significant amount of weight should be allowed to rest on the fan outlet flange, deck assemblies or condenser coil module. No more than 1 meter of light construction ductwork should be supported by the unit.

Where cross-winds may occur, any ductwork must be supported to prevent side loading on the unit. If the ducts from two or more fans are to be combined into a common duct, back-flow dampers should be fitted in the individual fan ducts. This will prevent re-circulation of air when only one of the fans is running.

Units are supplied with outlet guards for safety and to prevent damage to the fan blades. If these guards are removed to fit ductwork, adequate alternative precautions must be taken to ensure persons cannot be harmed or put at risk from rotating fan blades.

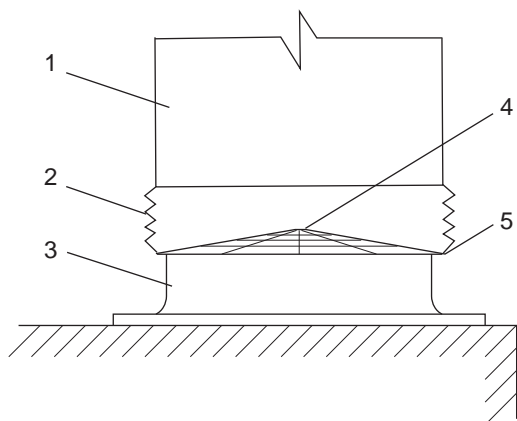

- | | |
|-----------------|----------------|
| 1 Solid Duct | 4 Fan Guard |
| 2 Flexible Duct | 5 Backing Ring |
| 3 Fan | |

Location Clearances

Adequate clearances around the unit(s) are required for the unrestricted air-flow for the air-cooled condenser coils and to prevent re-circulation of warm discharge air back onto the coils. If clearances given are not maintained, air-flow restriction or re-circulation will cause a loss of unit performance, an increase in power consumption, and may cause the unit to malfunction. Consideration should also be given to the possibility of down drafts, caused by adjacent buildings, which may cause re-circulation or uneven unit air-flow.

For locations where significant cross winds are expected, such as exposed roof tops, an enclosure of solid or louvre type is recommended to prevent wind turbulence interfering with the unit air-flow.

When units are installed in an enclosure, the enclosure height should not exceed the height of the unit on more than one side. If the enclosure is of louvred construction, the same requirement of static pressure loss applies as for ducts and attenuators stated above. Where accumulation of snow is likely, additional height must be provided under the unit to ensure normal air-flow to the unit.

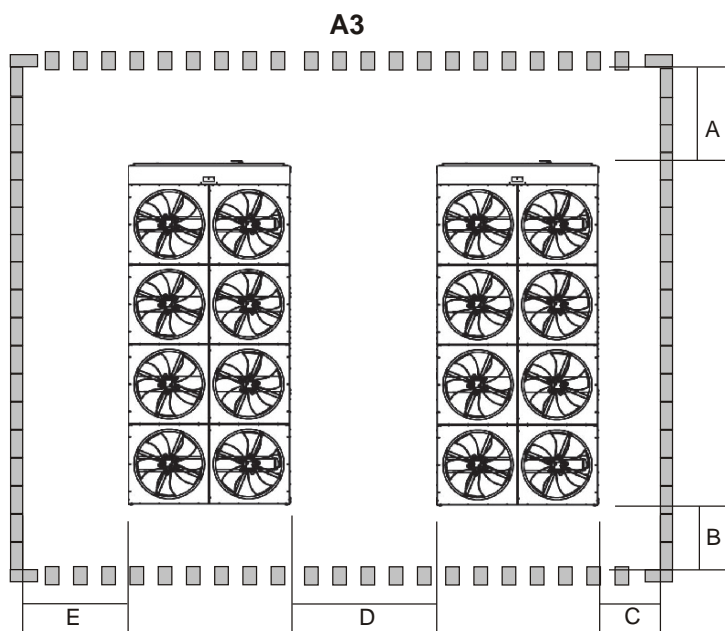
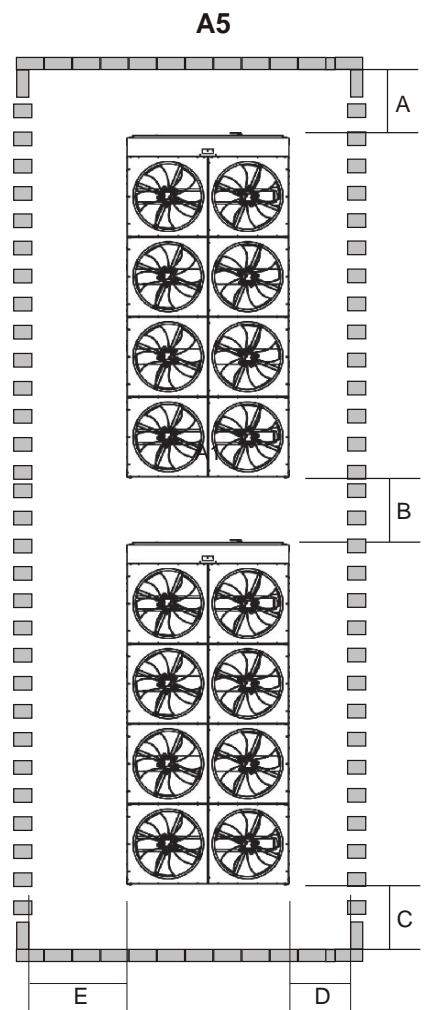
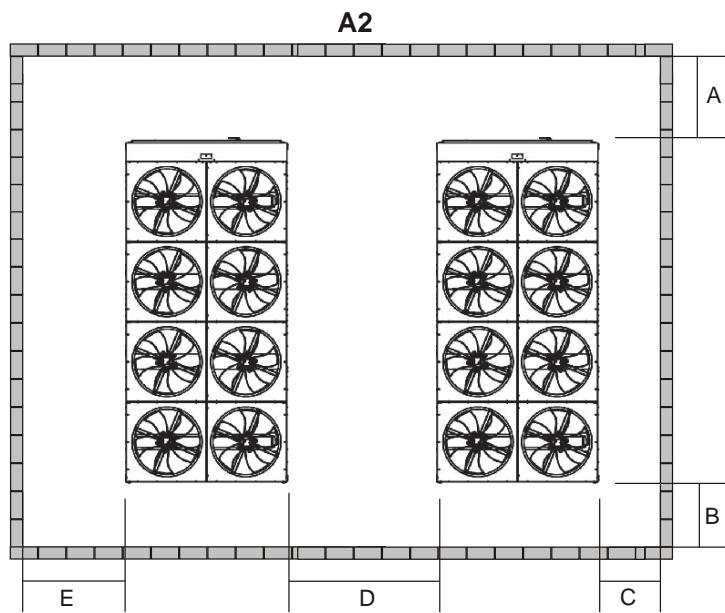
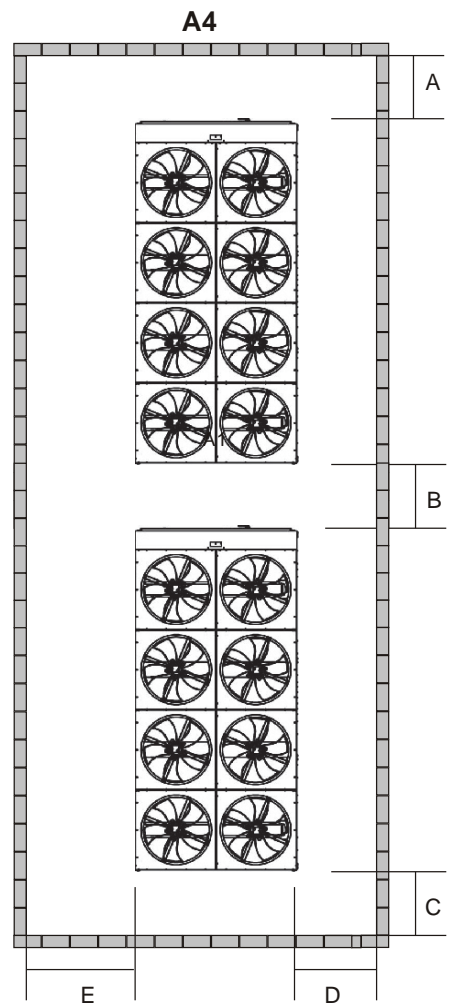
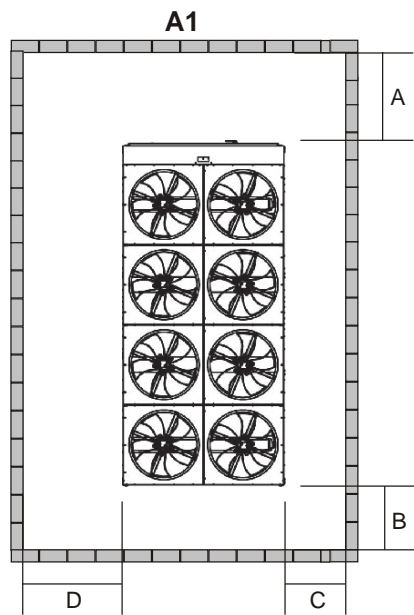

Location Clearances - SE & SELS Models

YLAA	Dim. (m)	YLAA-SE			YLAA-SE-LS		
		0180 0210 0240 0285 0320	0360 0400	0435 0485	0180 0210 0240 0285 0320	0360 0400	0435 0485
Arrangement A1 Solid Walls	A	1.2	1.2	1.2	1.2	1.2	1.2
	B	0.8	0.8	0.8	0.8	0.8	0.8
	C	0.8	0.8	0.8	0.8	0.8	0.8
	D	1.4	1.4	1.4	1.4	1.4	1.4
Arrangement A2 Solid Walls	A	1.2	1.2	1.2	1.2	1.2	1.2
	B	0.8	0.8	0.8	0.8	0.8	0.8
	C	0.8	0.8	0.8	0.8	0.8	0.8
	D	1.9	2.2	2.7	1.6	1.9	2.2
	E	1.4	1.4	1.4	1.4	1.4	1.4
Arrangement A3 Louvres on 2 walls	A	1.2	1.2	1.2	1.2	1.2	1.2
	B	0.8	0.8	0.8	0.8	0.8	0.8
	C	0.8	0.8	0.8	0.8	0.8	0.8
	D	1.7	1.8	2.3	1.4	1.7	2
	E	1.4	1.4	1.4	1.4	1.4	1.4
Arrangement A4 Solid Walls	A	1.2	1.2	1.2	1.2	1.2	1.2
	B	1.2	1.2	1.2	1.2	1.2	1.2
	C	0.8	0.8	0.8	0.8	0.8	0.8
	D	1.0	1.3	1.5	1.0	1.0	1.4
	E	1.4	1.4	1.5	1.4	1.4	1.4
Arrangement A5 Louvres on 2 walls	A	1.2	1.2	1.2	1.2	1.2	1.2
	B	1.2	1.2	1.2	1.2	1.2	1.2
	C	0.8	0.8	0.8	0.8	0.8	0.8
	D	0.8	0.8	0.8	0.8	0.8	0.8
	E	1.4	1.4	1.4	1.4	1.4	1.4

Location Clearances - HE & HELS Models

YLAA	Dim. (m)	YLAA-HE					YLAA-HE-LS				
		0195 0260	0300	0350 0390	0440	0455 0515	0195 0260	0300	0350 0390	0440	0455 0515
Arrangement A1 Solid Walls	A	1.2	1.2	1.2	1.2	1.2	1.2	1.2	1.2	1.2	1.2
	B	0.8	0.8	0.8	0.8	0.8	0.8	0.8	0.8	0.8	
	C	0.8	0.8	0.8	0.8	0.8	0.8	0.8	0.8	0.8	
	D	1.4	1.4	1.4	1.4	1.4	1.4	1.4	1.4	1.4	
Arrangement A2 Solid Walls	A	1.2	1.2	1.2	1.2	1.2	1.2	1.2	1.2	1.2	
	B	0.8	0.8	0.8	0.8	0.8	0.8	0.8	0.8	0.8	
	C	0.8	0.8	0.8	0.8	0.8	0.8	0.8	0.8	0.8	
	D	1.9	2.2	2.7	2.7	3.0	1.6	1.9	2.2	2.2	2.6
	E	1.4	1.4	1.4	1.4	1.4	1.4	1.4	1.4	1.4	1.4
Arrangement A3 Louvres on 2 walls	A	1.2	1.2	1.2	1.2	1.2	1.2	1.2	1.2	1.2	
	B	0.8	0.8	0.8	0.8	0.8	0.8	0.8	0.8	0.8	
	C	0.8	0.8	0.8	0.8	0.8	0.8	0.8	0.8	0.8	
	D	1.7	1.8	2.3	2.3	2.8	1.4	1.7	2	2	2.2
	E	1.4	1.4	1.4	1.4	1.4	1.4	1.4	1.4	1.4	1.4
Arrangement A4 Solid Walls	A	1.2	1.2	1.2	1.2	1.2	1.2	1.2	1.2	1.2	
	B	1.2	1.2	1.2	1.2	1.2	1.2	1.2	1.2	1.2	
	C	0.8	0.8	0.8	0.8	0.8	0.8	0.8	0.8	0.8	
	D	1.0	1.3	1.5	1.5	1.7	1.0	1.0	1.4	1.4	1.4
	E	1.4	1.4	1.5	1.5	1.7	1.4	1.4	1.4	1.4	1.4
Arrangement A5 Louvres on 2 walls	A	1.2	1.2	1.2	1.2	1.2	1.2	1.2	1.2	1.2	
	B	1.2	1.2	1.2	1.2	1.2	1.2	1.2	1.2	1.2	
	C	0.8	0.8	0.8	0.8	0.8	0.8	0.8	0.8	0.8	
	D	0.8	0.8	0.8	0.8	0.8	0.8	0.8	0.8	0.8	
	E	1.4	1.4	1.4	1.4	1.4	1.4	1.4	1.4	1.4	

Installation of Vibration Isolators

An optional set of vibration isolators can be supplied loose with each unit.

Pipework Connection

The following piping recommendations are intended to ensure satisfactory operation of the unit. Failure to follow these recommendations could cause damage to the unit, or loss of performance, and may invalidate the warranty.

If an optional Hydrokit has not been selected, a flow switch must be installed in the customer pipework at the outlet of the evaporator as shown in the arrangement diagrams, and wired back to the control panel using screened cable. This is to prevent damage to the evaporator caused by inadequate liquid flow. To prevent turbulent flow, there must be straight pipework either side of the flow switch equal in length to at least 5 times the diameter of the pipe.

The flow switches used must have gold plated contacts for low voltage/current operation

Alternatively, a differential pressure switch fitted across an orifice plate may be used, preferably of the high/low limit type.

The liquid pumps installed in the pipework systems should discharge directly into the unit heat exchanger sections of the system. The pumps require an auto-starter (by others) to be wired to the control panel.

Pipework and fittings must be separately supported to prevent any loading on the heat exchanger(s). Flexible connections are recommended which will also minimize transmission of vibrations to the building. Flexible connections must be used if the unit is mounted on anti-vibration mounts as some movement of the unit can be expected in normal operation.

Pipework and fittings immediately next to the heat exchanger(s) should be readily demountable to enable cleaning prior to operation, and to facilitate visual inspection of the exchanger nozzles.

Each heat exchanger must be protected by a strainer, preferably of 20 mesh, fitted as close as possible to the liquid inlet connection, and provided with a means of local isolation.

The heat exchanger(s) must not be exposed to flushing velocities or debris released during flushing. It is recommended that a suitably sized by-pass and valve arrangement be installed to allow flushing of the pipework system. The by-pass can be used during maintenance to isolate the heat exchanger(s) without disrupting flow to other units.

Thermometer and pressure gauge connections should be provided on the inlet and outlet connections of each heat exchanger.

Drain and air vent connections should be provided at all low and high points in the pipework to permit drainage of the system, and to vent any air in the pipes.

Liquid systems at risk of freezing, due to low ambient temperatures, should be protected using insulation and heater tape and/or a suitable glycol solution. The liquid pumps must also be used to ensure liquid is circulated when the ambient temperature approaches freezing point. Insulation should also be installed around the heat exchanger nozzles.

Heater tape of 21 W/m under the insulation is recommended, supplied independently and controlled by an ambient temperature thermostat set to switch on at approximately 2.2°C above the freezing temperature of the chilled liquid.

The evaporator is protected by two heater mats placed under the insulation, which are powered from the unit control system power supply. During cold weather when there is a risk of freezing, chiller power should be left switched on to provide the freeze protection function unless the liquid systems have been drained.

Pipework Arrangement

The following are suggested pipework arrangements for single unit installations. For multiple unit installations, each unit should be piped as shown. These are recommendations of the Building Services Research Association.

Chilled Liquid System

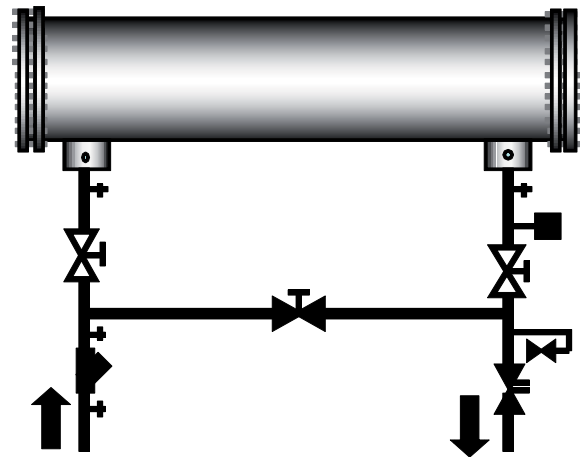

- + Pressure Tapping
- ⊠ Air vent
- ⊠ Flow Switch
- ⊠ Isolating Valve – Normally Open
- ⊠ Isolating Valve – Normally Closed
- ⊠ Flow Regulating Valve
- ⊠ Strainer

Connection Types and Sizes

Standard pipework connections are of the Victaulic groove type.

For connection sizes relevant to individual models refer to the physical data tables in this manual.

Heat Recovery System

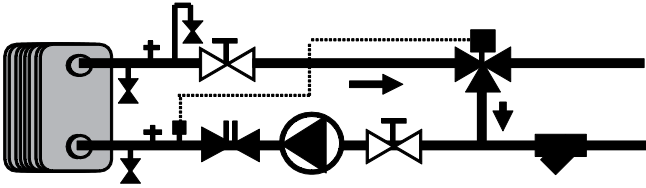

- † Pressure Tapping
- ⊥ Air vent
- ⊥ Drain
- ⊥ Isolating Valve – Normally Open
- ⊥ 3 Way Control Valve
- ⊥ Flow Regulating Valve
- ⊥ Strainer

Water Treatment

The unit performance given in the Design Guide is based on a fouling factor of 0.018 m² °C/kW . Dirt, scale, grease and certain types of water treatment will adversely affect the heat exchanger surfaces and therefore unit performance. Foreign matter in the water system(s) can increase the pressure drop, reducing the flow rate and causing potential damage.

Aerated, brackish or salt water is not recommended for use in the water systems. JCI recommends that a water treatment specialist be consulted to determine whether the proposed water composition will not affect the heat exchanger materials of carbon steel and copper. The pH value of the water flowing through the unit must be kept between 7 and 8.5.

Refrigerant Relief Valve Piping

The evaporator is protected against internal refrigerant overpressure by refrigerant relief valves. A pressure relief valve is mounted on each of the main refrigerant lines connecting the evaporator to the compressors.

For indoor installations, pressure relief valves should be piped to the exterior of the building.

The size of any pipework attached to a relief valve must be of sufficient diameter so as not to cause resistance to the operation of the valve. For critical or complex installations refer to EN13136.

Unless otherwise specified by local regulations, the internal diameter depends on the length of pipe required and can be estimated with the following formula:

$$D5=1.447 \times L$$

Where:

D = minimum pipe internal diameter (cm)

L = length of pipe (m).

If relief pipework is common to more than one valve its cross sectional area must be at least the total required by each valve. Valve types should not be mixed on a common pipe. Precautions should be taken to ensure that the exit of relief valves/vent pipe remain clear of obstructions at all times.

Electrical Connection

The following connection recommendations are intended to ensure safe and satisfactory operation of the unit. Failure to follow these recommendations could cause harm to persons, or damage to the unit, and may invalidate the warranty.

No additional controls (relays, etc.) should be mounted in the control panel. Power and control wiring not connected to the control panel should not be run through the control panel. If these precautions are not followed it could lead to a risk of electrocution. In addition, electrical noise could cause malfunctions or damage the unit and its controls.

Power Wiring

These units are suitable for 400 V, 3-phase, 50 Hz nominal supplies only.

All electrical wiring should be carried out in accordance with local regulations. Route properly sized cables to the cable entries in the bottom of the power panel.

In accordance with EN 60204 it is the responsibility of the user to install over current protection devices between the supply conductors and the power supply terminals on the unit.

To ensure that no eddy currents are set up in the power panel, the cables forming each 3 phase power supply must enter via the same cable entry.

All sources of supply to the unit must be taken via a common point of isolation (not supplied by JCI).

Single Point Power Supply Wiring

All models require one field provided 400 V, 3Ø, 50 Hz + PE (Protected Earth) supply to the unit with circuit protection.

Connect the 3-phase supply to the non-fused disconnect switch located in the power panel using M10 lugs.

Connect the earth wire to the main protective earth terminal located in the power panel.

Control Circuit Transformer

The control circuit transformer (400 V, 2Ø, 50 Hz) providing the 115 V, 1Ø, 50 Hz supply to the unit control system is fitted in a separate enclosure mounted on top of the control panel.

Remote Emergency Stop Device

If required, a remote emergency stop device may be wired into the unit. This device should be rated at 20 amps, 110 V, AC-15. The device should be wired into terminals L and 5 in the power panel after removing the factory fitted link.

Control Wiring - Voltage Free Contact

All wiring to the voltage free contact terminal block requires a supply provided by the customer maximum voltage 254 Vac, 28 Vdc.

The customer must take particular care deriving the supplies for the voltage free terminals with regard to a common point of isolation. Thus, these circuits when used must be fed via the common point of isolation so the voltage to these circuits is removed when the common point of isolation to the unit is opened. This common point of isolation is not supplied by JCI.

In accordance with EN 60204 it is recommended that the customer wiring to these terminals uses orange wires. This will ensure that circuits not switched off by the units supply disconnecting device are distinguished by colour, so that they can easily be identified as live even when the unit disconnecting devices are off. The YORK voltage free contacts are rated at 125 VA.

All inductive devices (relays) switched by the YORK voltage free contacts must have their coil suppressed using standard RC suppressors. If these precautions are not followed, electrical noise could cause malfunctions or damage to the unit and its controls.

Chilled Liquid Pump Starter

Terminals 23 and 24 close to start the liquid pump. This contact is closed if there is a 'Leaving Liquid Temperature Cutout' or any of the compressors are running or the daily schedule is not calling for a shutdown with the unit switch on.

The contact must be used to ensure that the pump is running in the event of a 'Leaving Liquid Temperature Cutout'.

The pump contact will not close to run the pump if the unit has been powered up for less than 30 seconds, or if the pump has run in the last 30 seconds, to prevent pump motor overheating.

Run Contacts

Terminals 25 and 26 close to indicate that refrigerant system 1 is running and terminals 27 and 28 close to indicate that refrigerant system 2 is running.

Alarm Contacts

Each refrigerant system has a voltage-free normally open contact that will close when control power is applied to the panel, if no fault conditions are present. When a fault occurs which locks a system out, or there is a power failure the contact opens. To obtain a system alarm signal, connect the alarm circuit to terminals 29 and 30 for No. 1 system and terminals 31 and 32 for No. 2 system.

Control Wiring - System Inputs

All wiring to the control terminal block (nominal 30 Vdc) must be run in screened cable, with the screen earthed at the panel end only. Run screened cable separately from mains cable to avoid electrical noise pick-up.

The voltage free contacts must be suitable for 30 Vdc (gold contacts recommended). If the voltage free contacts form part of a relay or contactor, the coil of the device must be suppressed using a standard RC suppressor. The above precautions must be taken to avoid electrical noise that could cause a malfunction or damage to the unit and its controls.

Flow Switch

A chilled liquid flow switch of suitable type must be connected to terminals 13 and 18 to provide adequate protection against loss of liquid flow.

Remote Start/Stop

Connect a remote switch to terminals 13 and 14 to provide remote start/stop control if required.

Remote Reset of Chilled Liquid Setpoint

The PWM input (terminals 13 and 20) allows reset of the chilled liquid setpoint by supplying a 'timed' contact closure.

Remote Load Limiting

Load limiting prevents the unit from loading beyond a desired value. The unit % load limit depends on the number of compressors on the unit. The load limit inputs to terminals 13 and 21 work in conjunction with the PWM input to terminals 13 and 20.

Fan Full Speed Inhibit

The fan full speed inhibit input is 30 Vdc and the customer voltage free contact and wiring must be suitable for 30 Vdc.

To reduce unit noise the fans can be limited to run at a maximum step of all fans in star (reduced speed) i.e. fan full speed is inhibited. Connect a customer voltage free contact to terminals 13 & 16 in the fan panel. The contact must be rated for 30 Vdc, connecting wiring need to be run in screened cable. When the contact is closed fan full speed inhibit is in effect.

EMS Analogue Input

Provides a means of resetting the leaving chilled liquid temperature from the BAS/EMS. Accepts 4 to 20 mA, 0 to 20 mA, 0 to 10 Vdc or 2-10 Vdc. Connect to terminal A+ and A-. Disabled when using Modbus or BACnet MS/TP communications.

Modbus and BACnet MS/TP

Enable communications with building protocol systems using Modbus or BACnet protocol. Connect through standard RS485 port. Disabled when using EMS Analogue Input.

Connection Diagram

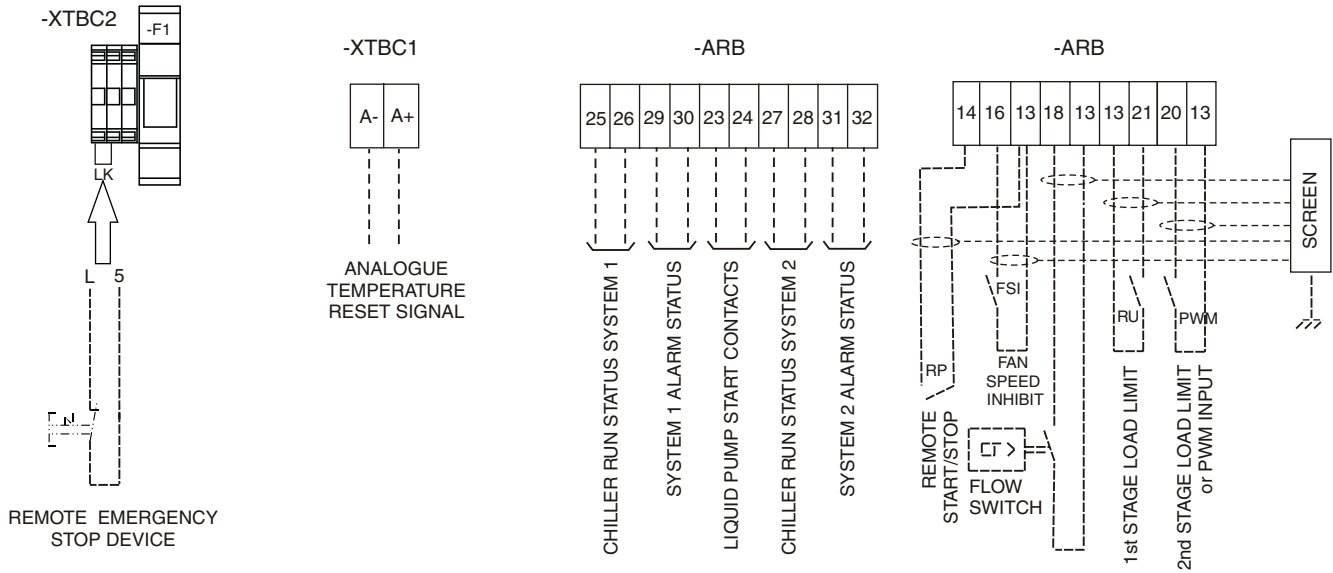

YLAA Customer Controls

Evaporator pressure drop graph

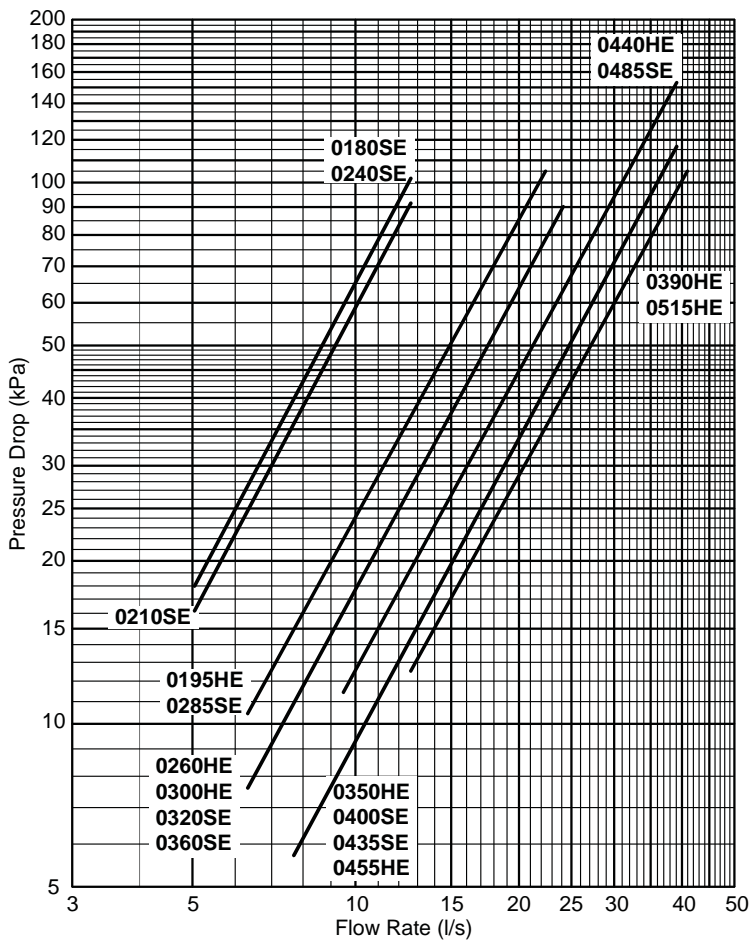

Operating Limitations - SE Models

YLAA SE			0180		0210		0240		0285		0320	
			Min.	Max.	Min.	Max.	Min.	Max.	Min.	Max.	Min.	Max.
Chilled Liquid	Liquid Outlet Temperature (Water)	°C	5 to 15									
	Liquid Outlet Temperature (Glycol)	°C	-1 to 15									
	Liquid Outlet Temperature Range	°C	3 to 8									
	Evaporator Flow Rate	l/s	5.0	12.6	5.0	12.6	5.0	12.6	6.3	22.4	6.3	24.3
	Evaporator Pressure Drop	kPa	18	103	16	92	18	103	10	105	8	91
	Maximum Water Side Pressure	bar	10									
Ambient Air	Air Temperature - Standard Unit	°C	-1 to 46 *									
	Air Temperature - Unit with Low Ambient Kit	°C	-18 to 46 *									
Maximum Refrigerant Side Pressure		bar	38.6									
Power Supply Voltage 400V, 3~, 50Hz (nominal)		V	360 to 440									

YLAA SE			0360		0400		0435		0485	
			Min.	Max.	Min.	Max.	Min.	Max.	Min.	Max.
Chilled Liquid	Liquid Outlet Temperature (Water)	°C	5 to 15							
	Liquid Outlet Temperature (Glycol)	°C	-1 to 15							
	Liquid Outlet Temperature Range	°C	3 to 8							
	Evaporator Flow Rate	l/s	6.3	24.3	7.6	39.4	7.6	39.4	9.5	39.4
	Evaporator Pressure Drop	kPa	8	91	6	118	6	118	11	154
	Maximum Water Side Pressure	bar	10							
Ambient Air	Air Temperature - Standard Unit	°C	-1 to 46 *							
	Air Temperature - Unit with Low Ambient Kit	°C	-18 to 46 *							
Maximum Refrigerant Side Pressure		bar	38.6							
Power Supply Voltage 400V, 3~, 50Hz (nominal)		V	360 to 440							

*: Unit may operate unloaded up to 52°C depending on model size and site conditions.

Operating Limitations - HE Models

YLAA HE			0195		0260		0300		0350	
			Min.	Max.	Min.	Max.	Min.	Max.	Min.	Max.
Chilled Liquid	Liquid Outlet Temperature (Water)	°C	5 to 15							
	Liquid Outlet Temperature (Glycol)	°C	-1 to 15							
	Liquid Outlet Temperature Range	°C	3 to 8							
	Evaporator Flow Rate	L/s	6.3	22.4	6.3	24.3	6.3	24.3	7.6	39.4
	Evaporator Pressure Drop	kPa	10	105	8	91	8	91	6	118
	Maximum Water Side Pressure	bar	10							
Ambient Air	Air Temperature - Standard Unit	°C	-1 to 46 *							
	Air Temperature - Unit with Low Ambient Kit	°C	-18 to 46 *							
Maximum Refrigerant Side Pressure		bar	38.6							
Power Supply Voltage 400V, 3~, 50Hz (nominal)		V	360 to 440							

YLAA HE			0390		0440		0455		0515	
			Min.	Max.	Min.	Max.	Min.	Max.	Min.	Max.
Chilled Liquid	Liquid Outlet Temperature (Water)	°C	5 to 15							
	Liquid Outlet Temperature (Glycol)	°C	-1 to 15							
	Liquid Outlet Temperature Range	°C	3 to 8							
	Evaporator Flow Rate	L/s	12.6	41.0	9.5	39.4	7.6	39.4	12.6	41.0
	Evaporator Pressure Drop	kPa	13	105	11	154	6	118	13	105
	Maximum Water Side Pressure	bar	10							
Ambient Air	Air Temperature - Standard Unit	°C	-1 to 46 *							
	Air Temperature - Unit with Low Ambient Kit	°C	-18 to 46 *							
Maximum Refrigerant Side Pressure		bar	38.6							
Power Supply Voltage 400V, 3~, 50Hz (nominal)		V	360 to 440							

*: Unit may operate unloaded up to 52°C depending on model size and site conditions.

Cooling Capacities - Water Cooling - SE Models

LCLT °C	YLAA-SE	Condenser Coil Entering Air Temperature (°C)																	
		25			30			35			40			45			46		
		kW _o	kW _{ci}	EER	kW _o	kW _{ci}	EER	kW _o	kW _{ci}	EER	kW _o	kW _{ci}	EER	kW _o	kW _{ci}	EER	kW _o	kW _{ci}	EER
5°C	0180	188	46	3.65	179	52	3.16	169	57	2.71	157	63	2.30	145	70	1.94	142	71	1.87
	0210	207	61	3.13	196	68	2.70	185	75	2.31	172	83	1.95	157	91	1.63	110	55	1.83
	0240	228	60	3.43	217	66	2.99	205	73	2.57	191	81	2.18	176	89	1.84	173	91	1.77
	0285	291	77	3.49	277	85	3.03	261	94	2.60	242	103	2.20	170	75	2.09	167	76	2.01
	0320	329	92	3.32	311	102	2.87	293	112	2.46	271	124	2.08	143	58	2.22	141	59	2.14
	0360	363	97	3.44	345	108	2.97	326	119	2.55	302	132	2.15	232	105	2.04	228	107	1.97
	0400	409	115	3.31	388	127	2.86	365	140	2.45	337	154	2.07	208	90	2.11	204	92	2.03
	0435	442	117	3.47	420	129	3.01	395	143	2.58	366	157	2.19	289	133	2.02	284	136	1.95
	0485	495	138	3.34	469	152	2.89	441	168	2.47	408	185	2.09	275	122	2.07	270	125	2.00
6°C	0180	193	47	3.73	184	52	3.23	174	58	2.77	162	64	2.36	149	70	1.98	147	72	1.92
	0210	213	62	3.19	202	68	2.76	191	76	2.36	177	83	2.00	162	92	1.67	113	55	1.88
	0240	235	60	3.51	223	66	3.05	211	74	2.63	197	81	2.24	182	90	1.88	178	92	1.82
	0285	300	77	3.56	285	85	3.09	268	95	2.65	249	104	2.25	176	75	2.14	173	77	2.07
	0320	338	93	3.39	320	103	2.92	301	113	2.51	278	125	2.12	148	58	2.28	145	59	2.20
	0360	373	98	3.50	355	109	3.03	335	120	2.60	311	133	2.20	239	106	2.10	235	108	2.02
	0400	421	116	3.37	399	128	2.92	375	142	2.50	347	156	2.11	214	91	2.16	211	93	2.09
	0435	455	118	3.54	431	131	3.07	407	144	2.64	377	158	2.24	298	134	2.07	293	137	2.00
	0485	509	140	3.40	482	154	2.94	454	170	2.52	419	187	2.13	283	123	2.13	278	125	2.05
7°C	0180	199	47	3.81	189	52	3.30	179	58	2.84	167	64	2.41	154	71	2.03	151	72	1.96
	0210	219	62	3.25	208	69	2.82	196	76	2.41	182	84	2.04	119	55	2.00	117	56	1.93
	0240	242	61	3.59	230	67	3.12	218	74	2.69	203	82	2.29	187	90	1.93	184	92	1.86
	0285	308	78	3.63	292	86	3.15	276	95	2.71	256	105	2.29	181	76	2.19	178	77	2.12
	0320	347	94	3.44	329	104	2.98	310	114	2.56	286	126	2.16	153	59	2.34	150	60	2.26
	0360	384	99	3.57	365	110	3.09	344	121	2.66	320	134	2.25	247	106	2.15	242	109	2.07
	0400	432	118	3.43	409	130	2.97	386	143	2.55	356	157	2.16	221	91	2.22	217	93	2.14
	0435	468	120	3.61	444	132	3.13	418	145	2.69	388	160	2.28	307	135	2.12	301	137	2.04
	0485	523	141	3.46	495	156	2.99	466	172	2.57	431	188	2.17	292	124	2.18	287	126	2.10

Notes: kW_o = Full load cooling capacity (kW) kW_{ci} = Input power to all compressors (kW) EER = Energy Efficiency Ratio (includes compressors and fans)

Data based on 5°C chilled water temperature difference and 0.018 m³/C/kW

Units with two speed fans:

The data in the tables is for normal fan speed operation. Fans will operate at low speed when the ambient is at 27°C or below.

For low speed fan operation cooling capacities and compressor kW at 25°C ambient see LS chiller data.

Cooling Capacities - Water Cooling - SE Models (Cont.)

LCLT °C	YLAA-SE	Condenser Coil Entering Air Temperature (°C)																	
		25			30			35			40			45			46		
		kW _o	kW _{ci}	EER	kW _o	kW _{ci}	EER	kW _o	kW _{ci}	EER	kW _o	kW _{ci}	EER	kW _o	kW _{ci}	EER	kW _o	kW _{ci}	EER
8°C	0180	205	48	3.90	195	53	3.38	184	59	2.90	172	65	2.47	158	71	2.08	156	73	2.01
	0210	225	63	3.31	214	69	2.87	202	77	2.46	187	85	2.09	123	55	2.05	121	56	1.98
	0240	249	61	3.67	237	67	3.19	224	75	2.75	209	82	2.34	193	91	1.97	189	93	1.90
	0285	317	79	3.69	301	87	3.20	284	96	2.76	263	106	2.34	187	76	2.25	183	78	2.17
	0320	357	95	3.50	338	105	3.03	318	115	2.60	294	127	2.20	158	59	2.40	155	60	2.32
	0360	394	100	3.64	375	111	3.15	354	122	2.71	328	135	2.30	254	107	2.20	249	109	2.12
	0400	444	119	3.49	421	131	3.02	396	144	2.60	366	158	2.20	228	92	2.27	224	94	2.19
	0435	480	121	3.67	456	133	3.19	430	147	2.74	399	161	2.33	316	136	2.17	310	138	2.09
10°C	0485	537	143	3.52	509	157	3.04	479	173	2.61	443	190	2.21	301	125	2.23	295	127	2.15
	0180	216	48	4.05	206	54	3.52	195	59	3.03	182	65	2.58	168	72	2.18	139	58	2.21
	0210	237	64	3.44	225	71	2.98	213	78	2.56	198	86	2.17	130	56	2.15	128	57	2.08
	0240	263	62	3.81	250	69	3.33	237	76	2.87	221	84	2.45	204	92	2.07	201	94	1.99
	0285	334	81	3.82	317	89	3.32	299	98	2.86	278	107	2.43	198	77	2.35	194	79	2.27
	0320	376	97	3.61	356	107	3.13	335	118	2.69	310	129	2.28	167	60	2.52	164	61	2.44
	0360	416	102	3.77	396	113	3.27	374	124	2.81	347	137	2.39	269	109	2.30	264	111	2.22
	0400	468	121	3.60	443	134	3.12	418	147	2.69	386	161	2.28	241	93	2.38	237	95	2.30
13°C	0435	507	123	3.80	481	136	3.30	454	149	2.85	421	164	2.42	335	138	2.27	282	110	2.34
	0485	566	146	3.63	536	161	3.14	504	176	2.70	467	193	2.29	319	127	2.33	313	129	2.25
	0180	234	50	4.29	224	55	3.74	212	61	3.22	198	67	2.75	154	58	2.45	152	59	2.37
	0210	256	66	3.61	243	73	3.13	230	80	2.70	214	88	2.30	142	57	2.31	114	42	2.41
	0240	285	64	4.04	272	70	3.53	257	78	3.05	240	85	2.61	222	94	2.20	218	96	2.13
	0285	361	83	4.01	343	92	3.49	324	101	3.01	300	110	2.57	215	79	2.51	136	44	2.68
	0320	405	101	3.77	384	111	3.27	362	121	2.82	334	133	2.40	183	61	2.70	180	62	2.61
	0360	450	105	3.95	427	116	3.44	404	128	2.97	375	140	2.52	292	111	2.45	253	94	2.46
0400	505	126	3.76	478	138	3.26	450	152	2.81	345	156	2.56	262	95	2.54	258	97	2.45	
0435	548	127	3.99	520	140	3.47	491	153	3.00	455	168	2.56	313	111	2.59	307	113	2.50	
0485	611	151	3.79	578	166	3.28	544	182	2.83	503	199	2.41	346	129	2.48	340	132	2.40	

Notes: kW_o = Full load cooling capacity (kW) kW_{ci} = Input power to all compressors (kW) EER = Energy Efficiency Ratio (includes compressors and fans)

Data based on 5°C chilled water temperature difference and 0.018 m³/C/kW

Units with two speed fans:

The data in the tables is for normal fan speed operation. Fans will operate at low speed when the ambient is at 27°C or below.

For low speed fan operation cooling capacities and compressor kW at 25°C ambient see LS chiller data.

Cooling Capacities - Water Cooling - HE Models

LCLT °C	YLAA-HE	Condenser Coil Entering Air Temperature (°C)																	
		25			30			35			40			45			46		
		kW _o	kWci	EER	kW _o	kWci	EER	kW _o	kWci	EER	kW _o	kWci	EER	kW _o	kWci	EER	kW _o	kWci	EER
5°C	0195	207	47	3.96	196	52	3.43	185	58	2.95	172	63	2.50	133	55	2.22	131	56	2.14
	0260	266	62	3.88	253	68	3.37	239	76	2.90	221	83	2.46	203	92	2.06	199	93	1.99
	0300	325	74	3.95	309	82	3.44	292	90	2.97	272	99	2.52	250	109	2.12	245	112	2.04
	0350	363	82	3.94	346	91	3.43	327	100	2.97	304	110	2.52	279	122	2.12	274	124	2.05
	0390	406	95	3.88	386	104	3.37	364	116	2.90	339	127	2.47	309	140	2.06	303	143	1.99
	0440	451	105	3.88	428	115	3.37	405	127	2.91	376	140	2.47	345	155	2.08	339	158	2.00
6°C	0455	473	108	3.89	450	119	3.40	426	132	2.93	396	145	2.50	365	160	2.11	359	163	2.04
	0515	548	127	3.91	521	140	3.40	492	154	2.93	456	170	2.49	419	187	2.09	411	191	2.01
	0195	212	47	4.05	202	52	3.51	191	58	3.01	177	64	2.56	138	55	2.28	135	56	2.20
	0260	274	62	3.96	260	69	3.45	246	76	2.96	228	84	2.52	209	92	2.11	205	94	2.09
	0300	334	75	4.04	318	82	3.52	301	91	3.03	280	100	2.58	257	110	2.17	253	112	2.09
	0350	374	83	4.02	356	91	3.51	337	101	3.03	313	111	2.58	288	122	2.17	283	125	2.10
7°C	0390	418	96	3.96	397	105	3.44	375	117	2.96	348	128	2.52	319	141	2.11	313	144	2.03
	0440	464	106	3.96	441	116	3.45	417	128	2.98	387	141	2.53	356	156	2.13	349	159	2.05
	0455	487	109	3.98	463	120	3.47	438	133	3.00	408	146	2.56	376	161	2.16	370	164	2.09
	0515	564	128	3.99	536	141	3.47	506	156	2.99	470	171	2.54	431	188	2.14	423	192	2.06
	0195	219	48	4.13	208	53	3.58	196	58	3.08	182	64	2.62	141	55	2.33	139	56	2.25
	0260	282	63	4.04	268	69	3.52	253	77	3.03	235	84	2.58	216	93	2.16	212	95	2.09
7°C	0300	344	75	4.12	328	83	3.59	310	92	3.10	288	101	2.64	265	111	2.22	260	113	2.14
	0350	385	84	4.11	366	92	3.59	346	102	3.10	322	112	2.64	297	123	2.23	291	126	2.15
	0390	431	97	4.04	409	106	3.51	386	117	3.03	358	129	2.57	328	142	2.16	322	145	2.08
	0440	478	107	4.04	454	117	3.52	429	129	3.04	399	142	2.59	366	157	2.18	360	160	2.10
	0455	501	110	4.06	477	121	3.55	451	134	3.07	420	147	2.62	388	162	2.21	381	165	2.14
	0515	580	129	4.07	551	142	3.55	521	157	3.06	483	172	2.60	444	190	2.19	436	193	2.11

Notes: kW_o = Full load cooling capacity (kW) kWci = Input power to all compressors (kW) EER = Energy Efficiency Ratio (includes compressors and fans)

Data based on 5°C chilled water temperature difference and 0.018 m³/C/kW

Units with two speed fans:

The data in the tables is for normal fan speed operation.

Fans will operate at low speed when the ambient is at 27°C or below.

For low speed fan operation cooling capacities and compressor kW at 25°C ambient see LS chiller data.

Cooling Capacities - Water Cooling - HE Models (Cont.)

LCLT °C	YLA A-HE	Condenser Coil Entering Air Temperature (°C)																	
		25			30			35			40			45			46		
		kW _o	kW _{ci}	EER	kW _o	kW _{ci}	EER	kW _o	kW _{ci}	EER	kW _o	kW _{ci}	EER	kW _o	kW _{ci}	EER	kW _o	kW _{ci}	EER
8°C	0195	225	48	4.21	214	53	3.65	202	59	3.14	187	65	2.67	146	56	2.39	143	57	2.30
	0260	290	64	4.13	275	70	3.59	260	77	3.10	242	85	2.63	222	94	2.22	218	95	2.14
	0300	354	76	4.20	337	84	3.67	319	92	3.16	296	101	2.70	273	112	2.27	268	114	2.19
	0350	396	84	4.19	377	93	3.66	356	102	3.17	331	113	2.70	305	124	2.28	300	126	2.20
	0390	443	98	4.12	421	107	3.59	397	118	3.09	368	130	2.63	340	143	2.22	332	146	2.13
	0440	492	108	4.12	468	118	3.60	442	130	3.11	410	143	2.65	377	158	2.23	370	161	2.15
10°C	0455	515	111	4.15	490	122	3.63	464	135	3.14	432	148	2.68	399	163	2.27	392	166	2.19
	0515	597	130	4.15	567	143	3.62	536	158	3.12	497	174	2.66	457	191	2.24	448	195	2.16
	0195	237	49	4.37	226	54	3.80	213	60	3.27	198	66	2.79	154	56	2.50	152	57	2.42
	0260	306	65	4.29	291	71	3.74	275	79	3.22	256	86	2.75	235	95	2.31	231	97	2.23
	0300	374	77	4.37	356	85	3.81	337	94	3.29	313	103	2.81	289	113	2.37	286	79	2.37
	0350	419	86	4.36	398	94	3.81	377	104	3.30	351	114	2.82	323	126	2.38	317	128	2.30
13°C	0390	469	100	4.28	445	109	3.73	420	120	3.22	390	132	2.74	358	145	2.31	358	145	2.31
	0440	520	110	4.28	494	120	3.74	467	133	3.23	434	146	2.76	399	160	2.33	392	163	2.24
	0455	544	113	4.32	519	124	3.78	491	137	3.27	457	150	2.80	422	165	2.37	415	168	2.29
	0515	631	133	4.31	599	146	3.76	566	161	3.24	525	177	2.77	483	194	2.33	445	121	2.58
	0195	257	51	4.60	245	56	4.01	231	61	3.47	215	67	2.96	168	57	2.67	131	40	2.87
	0260	332	67	4.52	316	73	3.95	298	81	3.41	277	88	2.91	255	97	2.46	95	26	2.89
13°C	0300	405	80	4.61	386	87	4.03	365	96	3.49	339	105	2.98	228	79	2.62	224	80	2.54
	0350	454	88	4.61	432	97	4.03	409	107	3.50	380	117	2.99	351	128	2.53	344	131	2.45
	0390	509	103	4.51	483	113	3.94	456	124	3.40	423	136	2.90	237	73	2.83	233	75	2.74
	0440	563	113	4.52	535	124	3.95	506	136	3.42	470	149	2.92	433	164	2.47	359	127	2.58
	0455	590	116	4.57	562	127	4.00	532	140	3.47	496	153	2.98	458	168	2.53	387	133	2.64
	0515	683	137	4.54	649	150	3.96	613	165	3.43	569	181	2.93	383	121	2.86	377	123	2.76

Notes: kW_o = Full load cooling capacity (kW) kW_{ci} = Input power to all compressors (kW) EER = Energy Efficiency Ratio (includes compressors and fans)

Data based on 5°C chilled water temperature difference and 0.018 m³/C/kW

Units with two speed fans:

The data in the tables is for normal fan speed operation.

Fans will operate at low speed when the ambient is at 27°C or below.

For low speed fan operation cooling capacities and compressor kW at 25°C ambient see LS chiller data.

Cooling Capacities - Water Cooling - SE-LS Models

LCLT °C	YLAA-SE LS	Condenser Coil Entering Air Temperature (°C)																																			
		25						30						35						40						45						46					
		kWo	kWci	EER	kWo	kWci	EER	kWo	kWci	EER	kWo	kWci	EER	kWo	kWci	EER	kWo	kWci	EER	kWo	kWci	EER	kWo	kWci	EER	kWo	kWci	EER									
5°C	0180	186	47	3.55	177	53	3.07	167	59	2.63	155	65	2.23	143	71	1.88	140	72	1.81	140	72	1.88	140	72	1.81	140	72	1.81									
	0210	204	63	3.00	193	70	2.59	182	77	2.21	168	85	1.86	111	55	1.86	109	56	1.79	109	56	1.86	109	56	1.79	109	56	1.79									
	0240	225	62	3.39	213	68	2.93	202	76	2.51	187	83	2.13	172	92	1.78	169	94	1.72	169	94	1.78	169	94	1.72	169	94	1.72									
	0285	286	80	3.37	271	88	2.91	255	98	2.49	235	107	2.10	167	77	2.04	164	79	1.97	164	79	2.04	164	79	1.97	164	79	1.97									
	0320	321	96	3.17	303	106	2.73	285	117	2.33	262	129	1.96	141	59	2.20	138	60	2.12	138	60	2.20	138	60	2.12	138	60	2.12									
	0360	356	101	3.31	338	112	2.86	318	124	2.44	294	137	2.06	227	108	1.99	223	110	1.91	223	110	1.99	223	110	1.91	223	110	1.91									
	0400	400	120	3.16	378	133	2.73	355	147	2.32	326	161	1.95	204	93	2.07	200	95	1.99	200	95	2.07	200	95	1.99	200	95	1.99									
	0435	433	122	3.35	410	135	2.89	386	149	2.48	356	163	2.09	282	137	1.96	237	110	2.03	237	110	1.96	237	110	2.03	237	110	2.03									
	0485	483	145	3.19	457	159	2.75	429	176	2.34	395	193	1.97	268	126	2.02	263	128	1.94	263	128	2.02	263	128	1.94	263	128	1.94									
	0180	192	48	3.63	182	53	3.13	172	59	2.69	160	65	2.28	147	72	1.92	145	73	1.85	145	73	1.92	145	73	1.85	145	73	1.85									
0210	210	64	3.06	199	70	2.64	187	78	2.26	173	86	1.91	114	55	1.91	112	56	1.84	112	56	1.91	112	56	1.84	112	56	1.84										
0240	231	62	3.46	220	69	2.99	208	76	2.57	193	84	2.18	178	93	1.82	174	94	1.76	174	94	1.82	174	94	1.76	174	94	1.76										
0285	294	81	3.43	278	89	2.97	262	98	2.54	242	108	2.14	172	78	2.09	168	43	2.25	168	43	2.09	168	43	2.25	168	43	2.25										
0320	330	97	3.22	312	107	2.78	293	118	2.37	269	130	2.00	146	60	2.26	143	61	2.18	143	61	2.26	143	61	2.18	143	61	2.18										
0360	366	102	3.38	347	113	2.91	327	125	2.49	302	138	2.10	234	109	2.03	229	111	1.96	229	111	2.03	229	111	1.96	229	111	1.96										
0400	411	122	3.22	388	134	2.77	365	148	2.37	336	163	1.99	210	93	2.12	206	95	2.04	206	95	2.12	206	95	2.04	206	95	2.04										
0435	445	123	3.41	422	136	2.95	397	150	2.52	367	165	2.13	291	138	2.00	245	111	2.08	245	111	2.00	245	111	2.08	245	111	2.08										
0485	497	146	3.24	470	161	2.79	441	178	2.38	406	195	2.01	277	127	2.07	272	129	1.99	272	129	2.07	272	129	1.99	272	129	1.99										
0180	197	48	3.70	187	53	3.20	177	59	2.75	165	65	2.33	152	72	1.97	149	73	1.90	149	73	1.97	149	73	1.90	149	73	1.90										
0210	216	64	3.12	205	71	2.69	193	79	2.30	178	87	1.95	118	55	1.96	116	56	1.89	116	56	1.96	116	56	1.89	116	56	1.89										
0240	238	63	3.53	226	69	3.06	214	77	2.63	199	84	2.23	183	93	1.87	180	95	1.80	180	95	1.87	180	95	1.80	180	95	1.80										
0285	302	82	3.49	286	90	3.02	269	99	2.59	249	109	2.19	177	78	2.14	171	43	2.31	171	43	2.14	171	43	2.31	171	43	2.31										
0320	339	99	3.28	320	108	2.83	301	120	2.42	277	131	2.04	150	60	2.32	147	61	2.24	147	61	2.32	147	61	2.24	147	61	2.24										
0360	376	103	3.43	357	114	2.96	336	127	2.54	311	139	2.14	241	110	2.08	208	93	2.10	208	93	2.08	208	93	2.10	208	93	2.10										
0400	422	123	3.27	399	135	2.82	374	150	2.41	345	164	2.03	216	94	2.17	213	96	2.09	213	96	2.17	213	96	2.09	213	96	2.09										
0435	457	125	3.47	433	137	3.00	408	151	2.57	377	166	2.18	257	109	2.21	252	111	2.13	252	111	2.21	252	111	2.13	252	111	2.13										
0485	510	148	3.29	482	163	2.84	452	179	2.43	417	197	2.04	285	128	2.11	280	130	2.04	280	130	2.11	280	130	2.04	280	130	2.04										

Notes: kWo = Full load cooling capacity (kW) kWci = Input power to all compressors (kW) EER = Energy Efficiency Ratio (includes compressors and fans)

Data based on 5°C chilled water temperature difference and 0.018 m³/C/kW

Cooling Capacities - Water Cooling - SE-LS Models (Cont.)

LCLT °C	Y/LAA-SE LS	Condenser Coil Entering Air Temperature (°C)																	
		25			30			35			40			45			46		
		kW _o	kW _{ci}	EER	kW _o	kW _{ci}	EER	kW _o	kW _{ci}	EER	kW _o	kW _{ci}	EER	kW _o	kW _{ci}	EER	kW _o	kW _{ci}	EER
8°C	0180	203	49	3.78	193	54	3.27	182	60	2.81	169	66	2.39	156	73	2.01	153	74	1.94
	0210	221	65	3.17	210	72	2.74	198	79	2.35	183	87	1.99	122	56	2.01	119	57	1.94
	0240	245	63	3.60	233	70	3.12	220	77	2.68	204	85	2.28	188	94	1.91	185	96	1.84
	0285	310	82	3.55	294	91	3.07	276	100	2.63	256	110	2.23	182	79	2.19	115	44	2.37
	0320	348	100	3.33	329	110	2.87	309	121	2.46	168	55	2.82	155	60	2.38	152	62	2.30
	0360	386	105	3.49	366	115	3.02	345	128	2.58	319	140	2.18	248	111	2.13	215	94	2.15
	0400	433	124	3.32	409	137	2.86	384	151	2.45	293	126	2.22	223	95	2.22	219	96	2.14
	0435	470	126	3.53	445	139	3.05	419	153	2.62	387	167	2.22	265	110	2.26	260	112	2.18
	0485	524	150	3.34	495	164	2.88	465	181	2.47	320	117	2.58	294	129	2.16	288	131	2.08
	10°C	0180	214	49	3.93	204	55	3.41	193	61	2.93	179	67	2.49	165	74	2.10	109	41
0210		233	66	3.28	222	73	2.84	209	81	2.44	194	89	2.07	129	56	2.11	127	57	2.03
0240		259	64	3.75	246	71	3.25	233	78	2.79	216	86	2.37	199	95	2.00	196	97	1.93
0285		327	84	3.67	310	93	3.18	291	102	2.73	210	73	2.72	124	43	2.59	122	44	2.50
0320		366	102	3.43	346	112	2.96	325	123	2.53	179	56	2.96	164	61	2.49	161	62	2.41
0360		407	107	3.61	386	118	3.12	364	130	2.68	285	102	2.64	231	93	2.33	164	58	2.56
0400		456	127	3.42	431	140	2.95	405	154	2.53	257	87	2.75	236	96	2.32	167	60	2.52
0435		495	129	3.65	469	141	3.16	442	156	2.71	355	130	2.59	281	112	2.37	210	77	2.50
0485		550	153	3.44	521	168	2.97	489	185	2.54	339	119	2.68	311	131	2.26	174	58	2.67
13°C		0180	232	51	4.15	221	56	3.61	209	62	3.11	195	68	2.65	122	41	2.66	120	42
	0210	252	68	3.44	239	75	2.99	226	83	2.57	210	91	2.18	141	57	2.26	112	43	2.34
	0240	280	66	3.95	267	73	3.43	252	80	2.96	235	88	2.52	216	97	2.12	84	26	2.72
	0285	352	87	3.83	334	96	3.32	314	105	2.86	228	74	2.88	136	44	2.78	134	45	2.69
	0320	394	106	3.56	372	116	3.08	350	127	2.64	195	57	3.16	179	62	2.67	176	64	2.57
	0360	439	110	3.77	417	121	3.27	393	134	2.81	309	105	2.80	183	58	2.85	180	59	2.76
	0400	491	132	3.55	464	145	3.07	435	159	2.64	279	89	2.92						
	0435	534	133	3.81	506	146	3.31	477	160	2.85	384	133	2.74	234	77	2.79	230	78	2.69
	0485	593	159	3.57	560	174	3.09	526	191	2.65	368	122	2.84	191	58	2.93			

Notes: kW_o = Full load cooling capacity (kW) kW_{ci} = Input power to all compressors (kW) EER = Energy Efficiency Ratio (includes compressors and fans)
 Data based on 5°C chilled water temperature difference and 0.018 m³/C/kW

Cooling Capacities - Water Cooling - HE-LS Models

LCLT °C	YLAA-HE LS	Condenser Coil Entering Air Temperature (°C)																													
		25						30						40						45						46					
		kW _o	kW _{ci}	EER	kW _o	kW _{ci}	EER	kW _o	kW _{ci}	EER	kW _o	kW _{ci}	EER	kW _o	kW _{ci}	EER	kW _o	kW _{ci}	EER	kW _o	kW _{ci}	EER									
5°C	0195	204	48	3.85	194	53	3.32	183	59	2.85	169	65	2.42	130	56	2.13	102	39	2.28	194	96	1.99	174	78	2.07						
	0260	261	64	3.80	248	71	3.29	234	78	2.82	216	86	2.38	198	95	2.05	144	78	2.07	194	96	1.99	174	78	2.07						
	0300	320	76	3.89	304	84	3.37	287	93	2.89	266	103	2.45	244	113	2.05	174	78	2.07	194	96	1.99	174	78	2.07						
	0350	358	85	3.89	340	93	3.38	321	103	2.91	298	114	2.47	273	125	2.06	268	128	1.99	268	128	2.06	268	128	1.99						
	0390	399	98	3.79	378	108	3.28	356	120	2.81	329	131	2.38	301	145	1.99	180	73	2.24	301	145	1.99	180	73	2.24						
	0440	444	108	3.81	421	119	3.30	397	132	2.84	368	145	2.40	337	159	2.01	278	124	2.10	337	159	2.01	278	124	2.10						
6°C	0455	466	111	3.86	443	123	3.35	418	136	2.88	389	149	2.45	358	164	2.05	351	168	1.98	351	168	2.05	351	168	1.98						
	0515	538	131	3.83	511	145	3.31	481	160	2.84	446	176	2.41	408	193	2.01	291	120	2.25	408	193	2.01	291	120	2.25						
	0195	210	48	3.92	200	54	3.39	188	59	2.91	174	65	2.47	135	56	2.19	105	40	2.34	174	65	2.47	135	56	2.34						
	0260	269	65	3.88	255	71	3.35	241	79	2.88	223	87	2.44	204	95	2.04	154	26	2.46	204	95	2.04	154	26	2.46						
	0300	329	77	3.96	313	85	3.44	295	94	2.95	274	103	2.50	251	114	2.10	180	79	2.12	251	114	2.10	180	79	2.12						
	0350	368	85	3.97	350	94	3.45	330	104	2.97	307	114	2.52	282	126	2.11	216	128	2.04	282	126	2.11	216	128	2.04						
7°C	0390	411	99	3.87	389	109	3.35	367	121	2.87	341	133	2.44	310	146	2.03	186	73	2.31	310	146	2.03	186	73	2.31						
	0440	457	109	3.89	433	120	3.37	409	133	2.90	379	146	2.46	347	160	2.06	287	125	2.15	347	160	2.06	287	125	2.15						
	0455	479	112	3.94	456	124	3.42	431	137	2.94	400	150	2.50	368	165	2.10	310	131	2.21	368	165	2.10	310	131	2.21						
	0515	554	132	3.90	525	146	3.38	495	161	2.90	459	177	2.46	420	195	2.06	300	121	2.31	420	195	2.06	300	121	2.31						
	0195	216	49	4.00	205	54	3.46	194	60	2.98	180	66	2.53	138	57	2.23	108	40	2.39	180	66	2.53	138	57	2.39						
	0260	277	65	3.96	263	72	3.42	248	80	2.94	229	87	2.49	210	96	2.08	154	26	2.54	210	96	2.08	154	26	2.54						
7°C	0300	338	78	4.04	321	86	3.50	304	95	3.01	282	104	2.56	190	78	2.27	186	79	2.18	282	104	2.56	186	79	2.18						
	0350	379	86	4.05	360	95	3.52	340	105	3.03	316	115	2.58	290	127	2.16	285	129	2.09	290	127	2.16	285	129	2.09						
	0390	423	100	3.94	401	110	3.41	377	122	2.93	349	134	2.48	320	147	2.08	194	74	2.39	320	147	2.08	194	74	2.39						
	0440	470	110	3.97	446	121	3.44	421	134	2.96	390	147	2.51	357	162	2.10	296	126	2.21	357	162	2.10	296	126	2.21						
	0455	493	113	4.02	469	125	3.49	443	138	3.01	412	151	2.56	379	167	2.15	319	132	2.26	379	167	2.15	319	132	2.26						
	0515	570	134	3.97	540	147	3.44	510	163	2.96	472	178	2.51	421	195	2.45	310	121	2.37	421	195	2.45	310	121	2.37						

Notes: kW_o = Full load cooling capacity (kW) kW_{ci} = Input power to all compressors (kW) EER = Energy Efficiency Ratio (includes compressors and fans)
 Data based on 5°C chilled water temperature difference and 0.018 m³/C/kW

Cooling Capacities - Water Cooling - HE-LS Models (Cont.)

LCLT °C	YLAA-HE LS	Condenser Coil Entering Air Temperature (°C)																	
		25			30			35			40			45			46		
		kW _o	kW _{ci}	EER	kW _o	kW _{ci}	EER	kW _o	kW _{ci}	EER	kW _o	kW _{ci}	EER	kW _o	kW _{ci}	EER	kW _o	kW _{ci}	EER
8°C	0195	222	49	4.08	211	54	3.53	199	60	3.04	185	66	2.58	114	39	2.55	112	40	2.46
	0260	285	66	4.03	270	73	3.49	255	80	3.00	236	88	2.54	148	61	2.25	80	26	2.61
	0300	348	79	4.12	331	87	3.57	312	96	3.08	290	105	2.61	194	78	2.31	191	80	2.23
	0350	390	87	4.13	370	96	3.59	350	106	3.10	325	116	2.63	298	128	2.21	293	130	2.13
	0390	435	101	4.02	412	111	3.48	388	123	2.99	359	135	2.53	200	73	2.50	198	74	2.43
	0440	483	111	4.04	459	122	3.51	433	135	3.02	401	148	2.56	310	124	2.34	305	126	2.26
10°C	0455	507	114	4.10	482	126	3.56	456	139	3.07	424	153	2.61	390	168	2.20	329	132	2.32
	0515	586	135	4.05	556	149	3.51	524	164	3.02	485	180	2.56	325	120	2.52	319	122	2.43
	0195	235	50	4.23	223	55	3.67	210	61	3.16	195	67	2.69	121	40	2.69	119	40	2.60
	0260	301	67	4.18	285	74	3.62	269	82	3.12	249	90	2.64	87	26	2.86	86	26	2.77
	0300	367	80	4.27	349	88	3.71	330	97	3.19	306	107	2.72	206	79	2.41	136	43	2.79
	0350	412	89	4.29	391	98	3.73	370	108	3.22	343	118	2.74	315	130	2.31	175	58	2.70
13°C	0390	460	103	4.16	435	114	3.61	410	125	3.10	380	137	2.63	215	74	2.66	212	75	2.57
	0440	510	114	4.19	484	125	3.64	457	137	3.13	424	151	2.66	329	126	2.45	253	91	2.55
	0455	536	116	4.25	509	128	3.70	481	141	3.20	448	155	2.72	355	131	2.51	348	134	2.43
	0515	618	138	4.19	586	152	3.63	553	167	3.13	512	183	2.66	345	121	2.64	339	124	2.55
	0195	254	52	4.44	241	57	3.87	228	63	3.34	212	69	2.85	132	40	2.90	130	41	2.80
	0260	325	69	4.39	309	76	3.81	291	84	3.29	270	92	2.80	95	26	3.12	94	26	3.02
13°C	0300	397	83	4.48	378	91	3.90	357	100	3.37	331	109	2.87	152	43	3.11	149	44	3.01
	0350	446	92	4.51	423	101	3.93	400	111	3.40	372	121	2.90	195	58	3.01	192	59	2.91
	0390	498	107	4.37	472	117	3.80	444	129	3.27	411	141	2.78	233	75	2.83	229	77	2.73
	0440	552	117	4.40	524	129	3.83	494	141	3.30	459	155	2.81	281	91	2.83	276	93	2.74
	0455	580	120	4.48	551	132	3.91	522	145	3.38	485	158	2.89	386	134	2.69	379	137	2.60
	0515	668	143	4.39	634	157	3.82	598	172	3.29	554	188	2.80	376	124	2.81	369	126	2.72

Notes: kW_o = Full load cooling capacity (kW) kW_{ci} = Input power to all compressors (kW) EER = Energy Efficiency Ratio (includes compressors and fans)
 Data based on 5°C chilled water temperature difference and 0.018 m³/C/kW

Fan Power Data

Values for fans used on system 2 on YLAA0180SE, YLAA0210SE and YLAA0195HE

Standard			Low Noise			Two Speed						High Head		
kW	FLA @400V	LRA @400V	kW	FLA @400V	LRA @400V	Slow			Fast			kW	FLA @400V	LRA @400V
						kW	FLA @400V	LRA @400V	kW	FLA @400V	LRA @400V			
0.9	2.8	9.6	0.6	1.3	4.6	0.6	1.3	4.6	0.9	2.8	9.6	1.9	3.4	11.9

Values are for each fan. (FLA: Full Load Amps; LRA: Lock Rotor Amps)

Values for fans used on all other models and on system 1 on YLAA0180SE, YLAA0210SE and YLAA0195HE

Standard			Low Noise			Two Speed						High Head		
kW	FLA @400V	LRA @400V	kW	FLA @400V	LRA @400V	Slow			Fast			kW	FLA @400V	LRA @400V
						kW	FLA @400V	LRA @400V	kW	FLA @400V	LRA @400V			
1.7	3.8	18.5	1.2	2.2	6.0	1.2	2.2	6.0	1.7	3.8	18.5	2.6	4.0	20.0

Values are for each fan. (FLA: Full Load Amps; LRA: Lock Rotor Amps)

Physical Data - SE Models

YLAA - SE			0180SE	0210SE	0240SE	0285SE	0320SE
Number of refrigerant circuits			2				
Refrigerant Charge ⁽¹⁾	Circuit 1 / Circuit 2	kg	21 / 15	25 / 15	24 / 23	26 / 24	26 / 26
Oil Charge	Circuit 1 / Circuit 2	L	12 / 6	12 / 6	10 / 10	11 / 10	11 / 11
Compressor	Number of compressors		3 / 2	2 / 2	2 / 2	2 / 2	2 / 2
	Type		Scroll				
Evaporator	Number		1				
	Type		Plate Heat Exchanger			Shell and Tubes	
	Water Volume	L	10	10	10	185	193
	Water Connections	Inch	2.5	2.5	2.5	6	6
Air Cooled Condenser	Total Coil Face Area	m ²	7.4	7.4	10.0	10.0	10.0
Condenser Fans	Number of Fans (circuit 1 / circuit 2)		2 / 2	2 / 2	2 / 2	2 / 2	2 / 2
	Total Air Flow - Standard Models	m ³ /s	19.5	19.5	26	26	26
	Total Air Flow - LS Models	m ³ /s	16.5	16.5	22	22	22
	Dual Speed Fans - High Speed Air Flow	m ³ /s	19.5	19.5	26	26	26
Dimensions	Dual Speed Fans - Low Speed Air Flow	m ³ /s	16.5	16.5	22	22	22
	Length	mm	2911	2911	2911	2911	2911
	Width	mm	2242	2242	2242	2242	2242
Basic Unit Weight	Height	mm	2508	2508	2508	2508	2508
	Shipping Weight	kg	1705	1739	1838	2183	2274
	Operating Weight	kg	1715	1749	1848	2367	2469
Additional Weight	Heat Recovery Models	kg	136	136	136	136	136
	Hydrokit - Single Pump / Motor - Maximum	kg	267	267	267	267	267
	Hydrokit - Dual Pump / Motor - Maximum	kg	439	439	439	439	439
	Unit Louvred Panels	kg	227	227	227	227	227
	Low Sound Units	kg	156	156	156	156	156

YLAA - SE			0360SE	0400SE	0435SE	0485SE
Number of refrigerant circuits			2			
Refrigerant Charge ⁽¹⁾	Circuit 1 / Circuit 2	kg	30 / 24	31 / 27	31 / 29	32 / 30
Oil Charge	Circuit 1 / Circuit 2	L	17 / 12	17 / 11	17 / 20	17 / 17
Compressor	Number of compressors		3 / 3	3 / 2	3 / 3	3 / 3
	Type		Scroll			
Evaporator	Number		1			
	Type		Shell and Tubes			
	Water Volume	L	193	208	208	250
	Water Connections	Inch	6	8	8	8
Air Cooled Condenser	Total Coil Face Area	m ²	12.6	12.6	15.0	15.0
Condenser Fans	Number of Fans (circuit 1 / circuit 2)		3 / 2	3 / 2	3 / 3	3 / 3
	Total Air Flow - Standard Models	m ³ /s	32.5	32.5	39	39
	Total Air Flow - LS Models	m ³ /s	27.5	27.5	33	33
	Dual Speed Fans - High Speed Air Flow	m ³ /s	32.5	32.5	39	39
Dimensions	Dual Speed Fans - Low Speed Air Flow	m ³ /s	27.5	27.5	33	33
	Length	mm	3690	3690	3690	3690
	Width	mm	2242	2242	2242	2242
Basic Unit Weight	Height	mm	2508	2508	2508	2508
	Shipping Weight	kg	3060	3131	2901	3039
	Operating Weight	kg	3254	3339	3108	3290
Additional Weight	Heat Recovery Models	kg	136	136	136	136
	Hydrokit - Single Pump / Motor - Maximum	kg	267	267	267	267
	Hydrokit - Dual Pump / Motor - Maximum	kg	439	439	439	439
	Unit Louvred Panels	kg	266	266	266	266
	Low Sound Units	kg	195	195	195	195

(1) Liquid sub-cooling measured at the liquid line should be between 8.5 and 11.0°C at circuit full load.
Sub-cooling is determined by the level of refrigerant charge in each system

Physical Data - HE Models

YLAA - HE			0195HE	260HE	0300HE	0350HE
Number of refrigerant circuits			2			
Refrigerant Charge ⁽¹⁾	Circuit 1 / Circuit 2	kg	22 / 15	24 / 24	28 / 24	29 / 27
Oil Charge	Circuit 1 / Circuit 2	L	12 / 6	10 / 10	11 / 10	11 / 11
Compressor	Number of compressors		3 / 2	2 / 2	2 / 2	2 / 2
	Type		Scroll			
Evaporator	Number		1			
	Type		Shell and Tubes			
	Water Volume	L	185	193	193	208
	Water Connections	Inch	6	6	6	8
Air Cooled Condenser	Total Coil Face Area	m ²	10.0	10.0	12.6	15.1
Condenser Fans	Number of Fans (circuit 1 / circuit 2)		2 / 2	2 / 2	3 / 2	3 / 3
	Total Air Flow - Standard Models	m ³ /s	26	26	32.5	39
	Total Air Flow - LS Models	m ³ /s	22	22	27.5	33
	Dual Speed Fans - High Speed Air Flow	m ³ /s	26	26	32.5	39
	Dual Speed Fans - Low Speed Air Flow	m ³ /s	22	22	27.5	33
Dimensions	Length	mm	2911	2911	3690	3690
	Width	mm	2242	2242	2242	2242
	Height	mm	2508	2508	2508	2508
Basic Unit Weight	Shipping Weight	kg	1980	2134	2847	2597
	Operating Weight	kg	2165	2328	3041	2805
Additional Weight	Heat Recovery Models	kg	136	136	136	136
	Hydrokit - Single Pump / Motor - Maximum	kg	253	253	253	253
	Hydrokit - Dual Pump / Motor - Maximum	kg	439	439	439	439
	Unit Louvred Panels	kg	227	227	266	266
	Low Sound Units	kg	156	156	195	195

YLAA - HE			0390HE	0440HE	0455HE	0515HE
Number of refrigerant circuits			2			
Refrigerant Charge ⁽¹⁾	Circuit 1 / Circuit 2	kg	33 / 28	38 / 28	37 / 35	39 / 39
Oil Charge	Circuit 1 / Circuit 2	L	17 / 10	17 / 11	17 / 20	17 / 17
Compressor	Number of compressors		3 / 2	3 / 2	3 / 3	3 / 3
	Type		Scroll			
Evaporator	Number		1			
	Type		Shell and Tubes			
	Water Volume	L	293	250	208	293
	Water Connections	Inch	8	8	8	8
Air Cooled Condenser	Total Coil Face Area	m ²	15.1	17.6	20.1	20.1
Condenser Fans	Number of Fans (circuit 1 / circuit 2)		3 / 3	4 / 3	4 / 4	4 / 4
	Total Air Flow - Standard Models	m ³ /s	39	45.5	52	52
	Total Air Flow - LS Models	m ³ /s	33	39	44	44
	Dual Speed Fans - High Speed Air Flow	m ³ /s	39	45.5	52	52
	Dual Speed Fans - Low Speed Air Flow	m ³ /s	33	39	44	44
Dimensions	Length	mm	3690	4807	4807	4807
	Width	mm	2242	2242	2242	2242
	Height	mm	2508	2508	2508	2508
Basic Unit Weight	Shipping Weight	kg	2859	3583	3695	3900
	Operating Weight	kg	3151	3833	3902	4192
Additional Weight	Heat Recovery Models	kg	136	136	136	136
	Hydrokit - Single Pump / Motor - Maximum	kg	253	253	253	253
	Hydrokit - Dual Pump / Motor - Maximum	kg	439	439	439	439
	Unit Louvred Panels	kg	266	317	317	317
	Low Sound Units	kg	195	195	195	195

(1) Liquid sub-cooling measured at the liquid line should be between 8.5 and 11.0°C at circuit full load.
Sub-cooling is determined by the level of refrigerant charge in each system

Electrical Data SE Models

YLAA	Nominal Running Conditions		Maximum Running Conditions			Start up Amps	
	kW	Amps ⁽¹⁾ @ 400 V	kW	Amps ⁽²⁾ @360V	Amps ⁽²⁾ @ 400V	Direct on Line (3)	Optional Soft Start ^(3&4)
	without Power Factor Correction						
	with Optional Power Factor Correction Fitted						
0180SE	62	113	78	142	135	290	233
	62	104	78	136	127	283	227
0210SE	80	138	98	176	164	414	289
	80	130	98	170	157	409	286
0240SE	79	139	104	185	175	418	259
	79	131	104	180	168	412	255
0285SE	105	178	122	216	202	450	325
	105	171	122	211	195	444	321
0320SE	125	208	140	247	230	480	355
	125	201	140	241	223	474	351
0360SE	134	229	155	274	258	501	376
	134	218	155	267	248	492	369
0400SE	156	260	175	309	287	532	407
	156	250	175	301	278	524	401
0435SE	180	301	186	330	311	573	448
	180	286	186	319	296	560	438
0485SE	186	311	210	371	345	583	458
	186	299	210	362	334	573	450

(1) Nominal running amps at 35°C ambient air temperature and 7°C leaving chilled liquid temperature

(2) Maximum running amps at maximum operating conditions before compressor unloading

(3) Start up amps is the largest compressor starting with all other compressors/fans operating at nominal conditions at 400V.

(4) Soft Start is only fitted on the largest compressor in each system

Electrical Data HE Models

YLAA	Nominal Running Conditions		Maximum Running Conditions			Start up Amps	
	kW	Amps ⁽¹⁾ @ 400 V	kW	Amps ⁽²⁾ @360V	Amps ⁽²⁾ @ 400V	Direct on Line (3)	Optional Soft Start ^(3&4)
	without Power Factor Correction						
	with Optional Power Factor Correction Fitted						
0195HE	66	119	78	142	135	294	237
	66	110	78	136	127	287	232
0260HE	86	149	104	185	175	424	268
	86	141	104	180	168	419	264
0300HE	76	173	124	220	206	449	324
	76	165	124	214	199	443	320
0350HE	115	197	143	255	237	473	348
	115	189	143	249	230	467	344
0390HE	133	227	159	282	264	502	377
	133	217	159	275	255	495	371
0440HE	145	246	178	316	295	522	397
	145	236	178	309	286	514	391
0455HE	169	289	189	337	318	565	440
	169	274	189	326	303	551	429
0515HE	175	296	213	378	352	572	447
	175	284	213	369	341	562	439

(1) Nominal running amps at 35°C ambient air temperature and 7°C leaving chilled liquid temperature

(2) Maximum running amps at maximum operating conditions before compressor unloading

(3) Start up amps is the largest compressor starting with all other compressors/fans operating at nominal conditions at 400V.

(4) Soft Start is only fitted on the largest compressor in each system

Dimensions - YLAA0180SE & YLAA0210SE

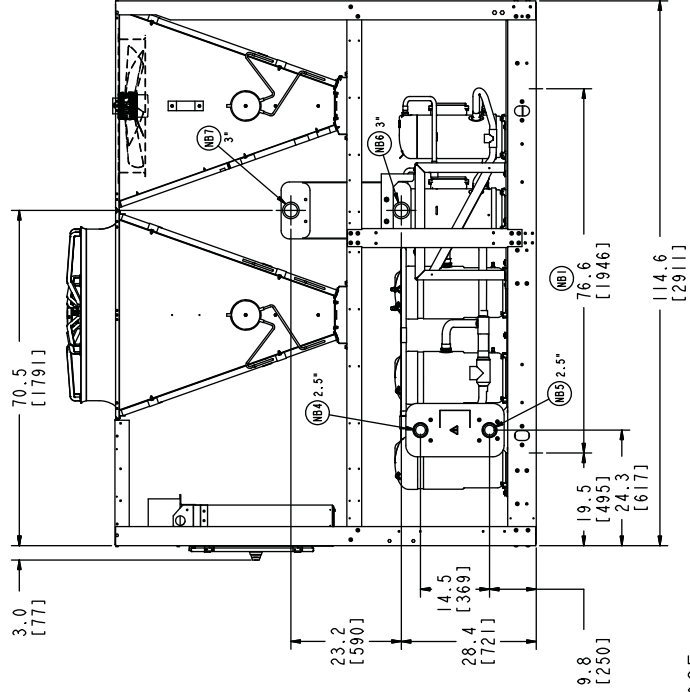
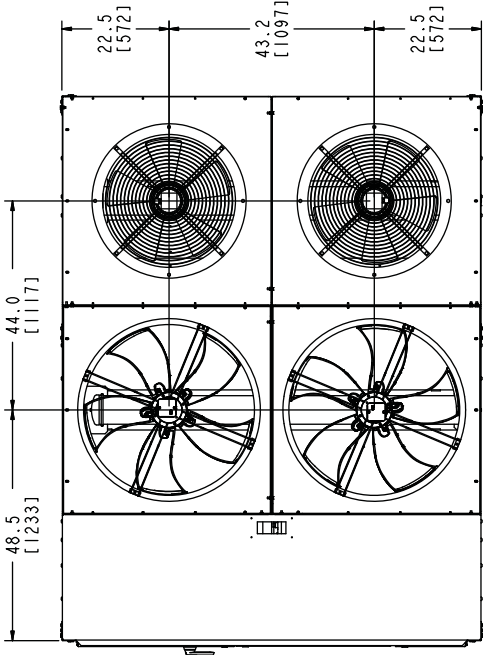

YLAA 0180SE
YLAA 0210SE

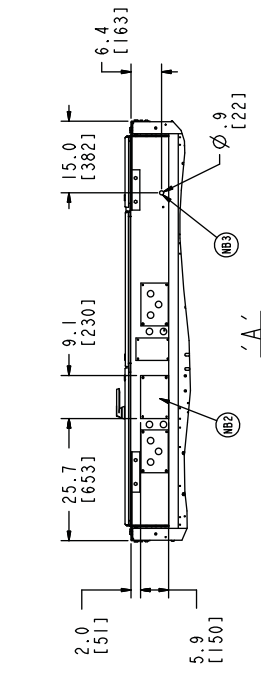

NB1
Distance between anti vibration mounts

NB2
Power cable entry via gland plate

NB3
Control cable entry

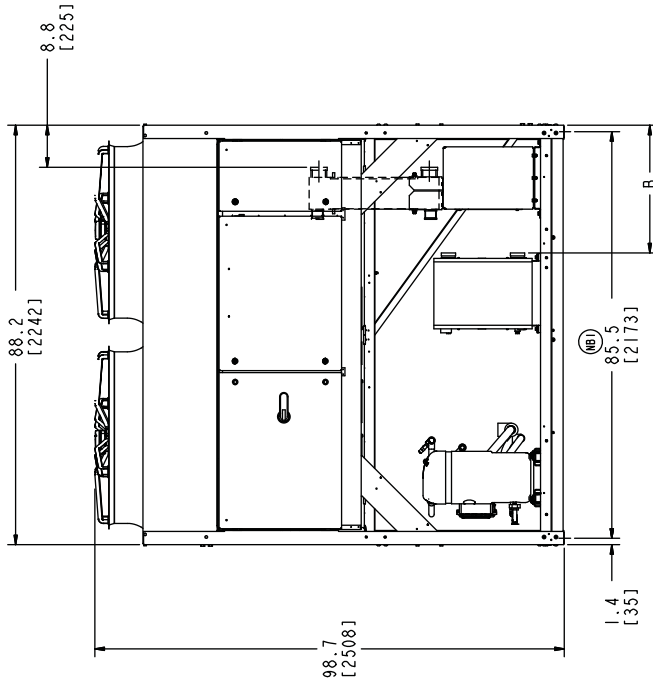

NB4
Chilled water inlet connection to evaporator

NB5
Chilled water outlet connection to evaporator

NB6
Hot water inlet connection to optional heat recovery exchanger

NB7
Hot water outlet connection to optional heat recovery exchanger

	B
YLAA 0180SE	26.9 [683]
YLAA 0210SE	24.8 [630]



Dimensions - YLAA0195HE

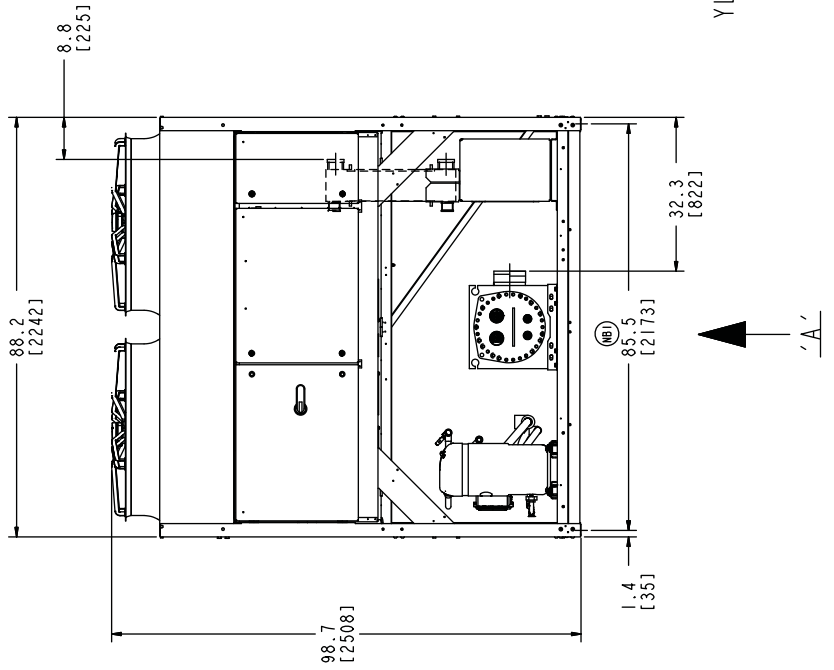
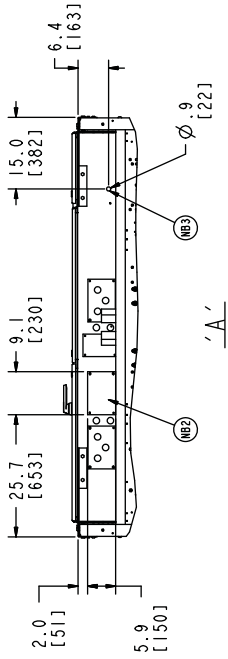
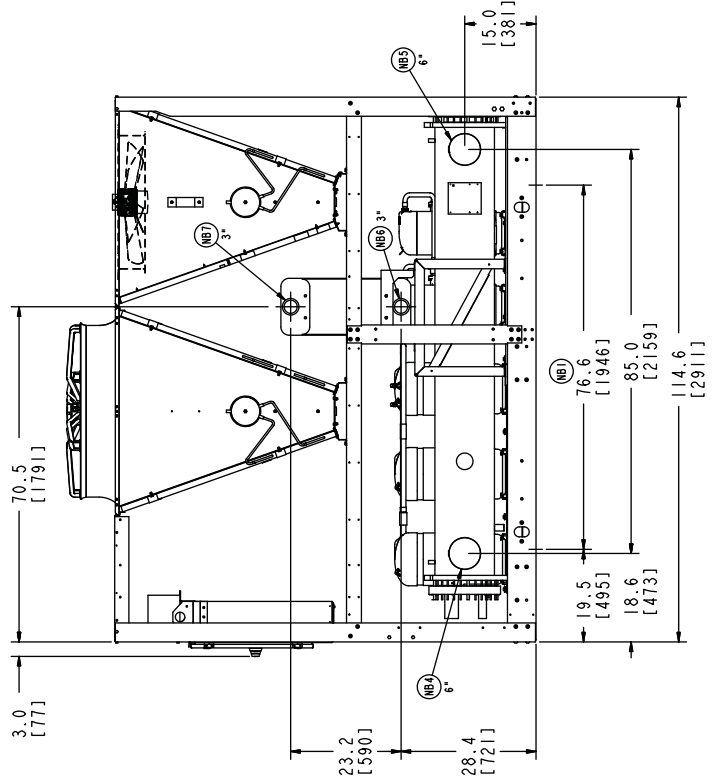
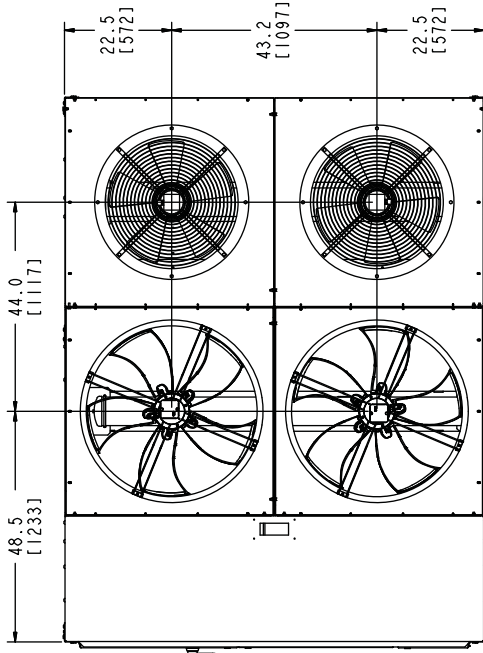

- NB1 Distance between anti vibration mounts
- NB2 Power cable entry via gland plate
- NB3 Control cable entry
- NB4 Chilled water inlet connection to evaporator
- NB5 Chilled water outlet connection to evaporator
- NB6 Hot water inlet connection to optional heat recovery exchanger
- NB7 Hot water outlet connection to optional heat recovery exchanger

YLAA 0195HE

Dimensions - YLAA0240SE

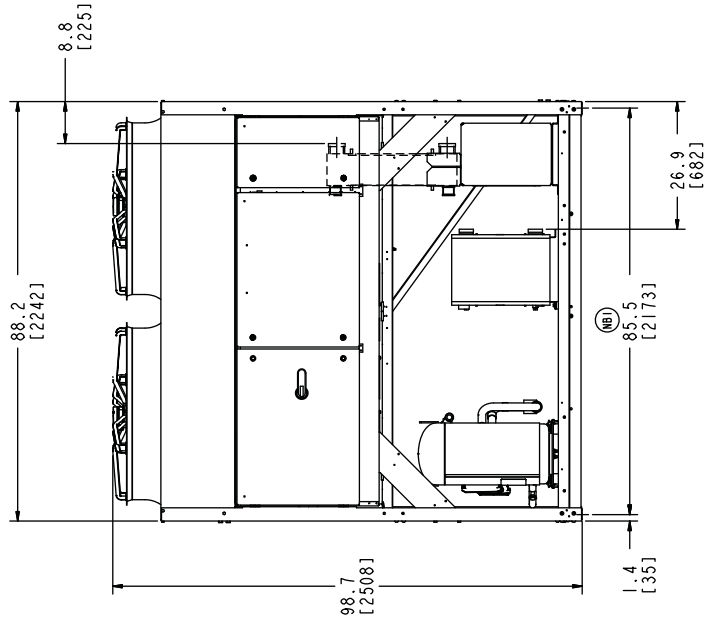
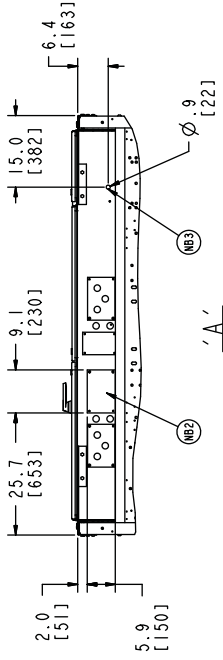
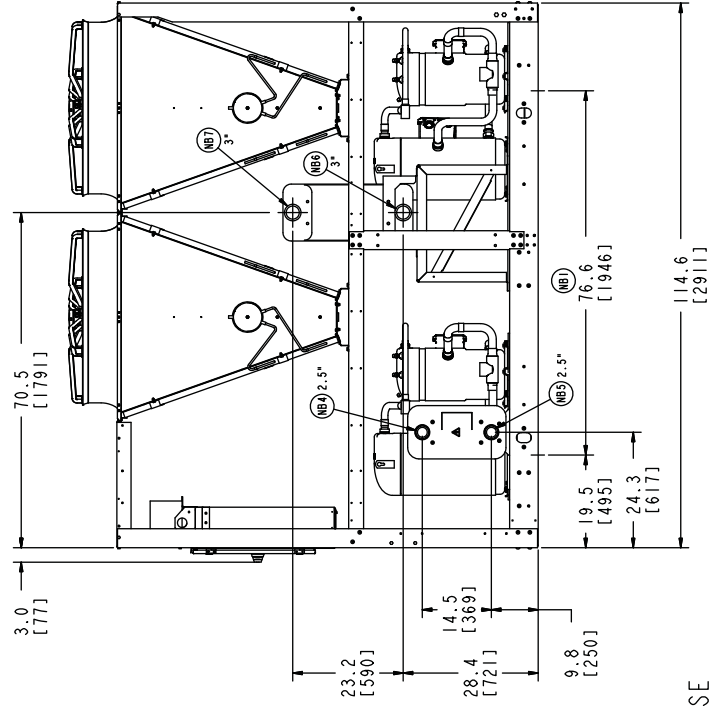
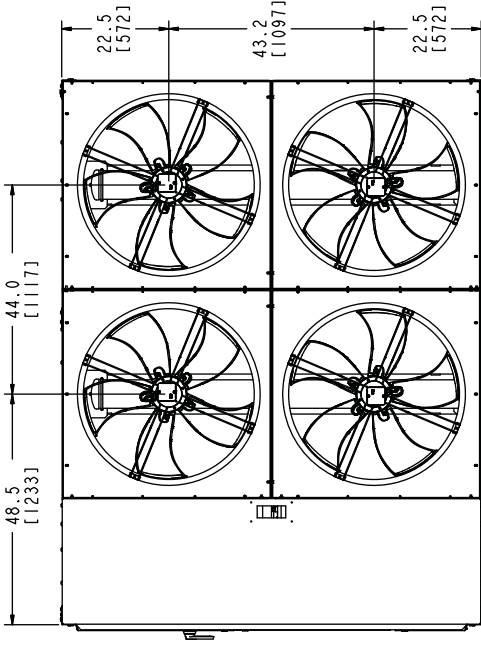

- NB1 Distance between anti vibration mounts
- NB2 Power cable entry via gland plate
- NB3 Control cable entry
- NB4 Chilled water inlet connection to evaporator
- NB5 Chilled water outlet connection to evaporator
- NB6 Hot water inlet connection to optional heat recovery exchanger
- NB7 Hot water outlet connection to optional heat recovery exchanger



YLAA 0240SE

Dimensions - YLAA0260HE, YLAA0285SE & YLAA0320SE

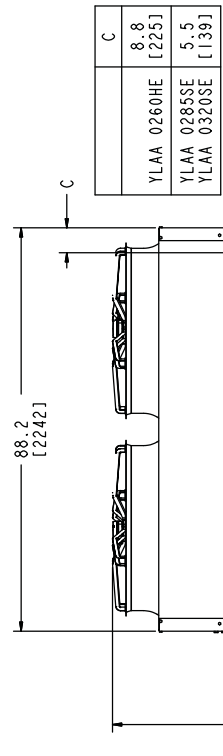
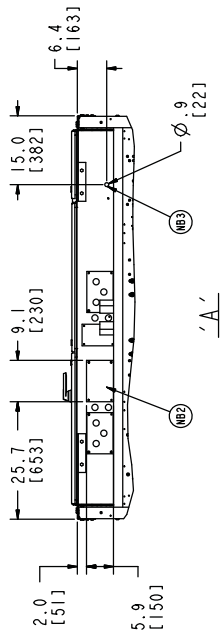
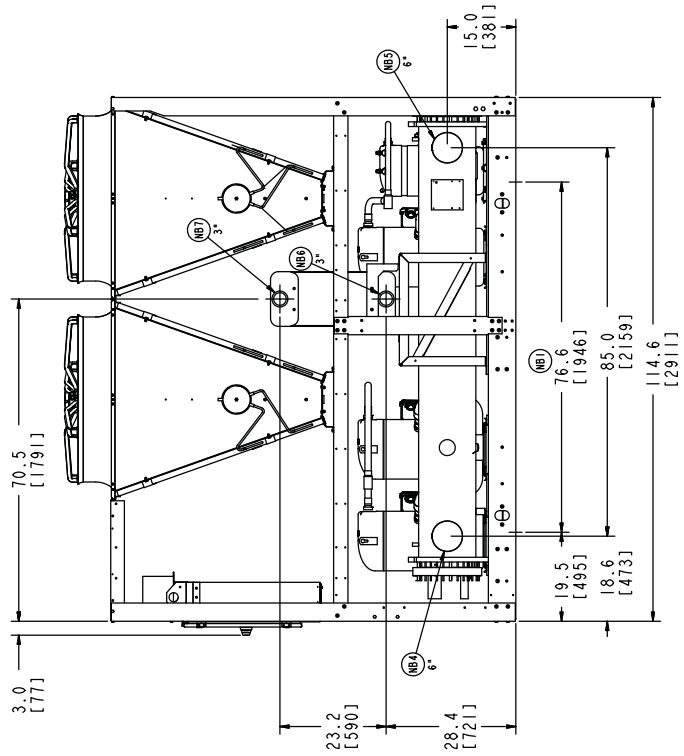
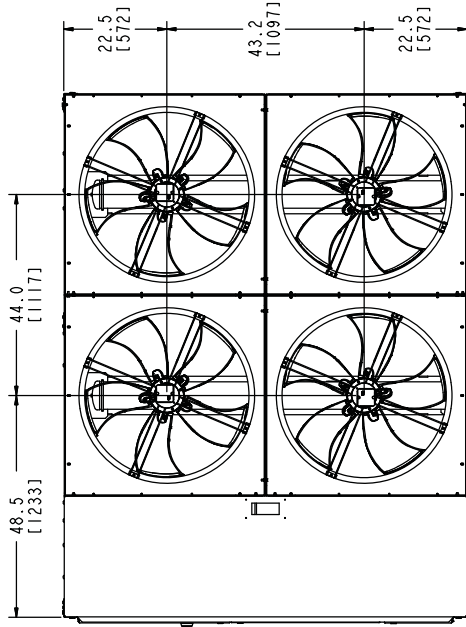

	C
YLAA 0260HE	8.8 [225]
YLAA 0285SE	5.5 [139]
YLAA 0320SE	

YLAA 0260HE
YLAA 0285SE
YLAA 0320SE

	B
YLAA 0285SE	32.3 [822]
YLAA 0260HE	30.7 [767]
YLAA 0320SE	

- NBNB1 Disinfectant between antimicrobial moments
- NBNB2 Power wash table entry via the top plate
- NBNB3 Control table entry
- NBNB4 Cold water inlet connection to evaporator
- NBNB5 Cold water outlet connection to evaporator
- NBNB6 Hot water inlet connection to optional heat recovery exchanger
- NBNB7 Hot water inlet connection to optional heat recovery exchanger

Dimensions - YLAA0300HE, YLAA0360SE & YLAA0400SE

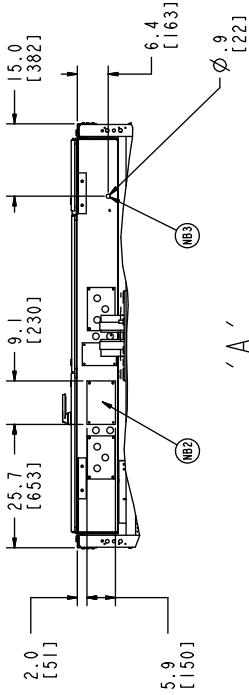
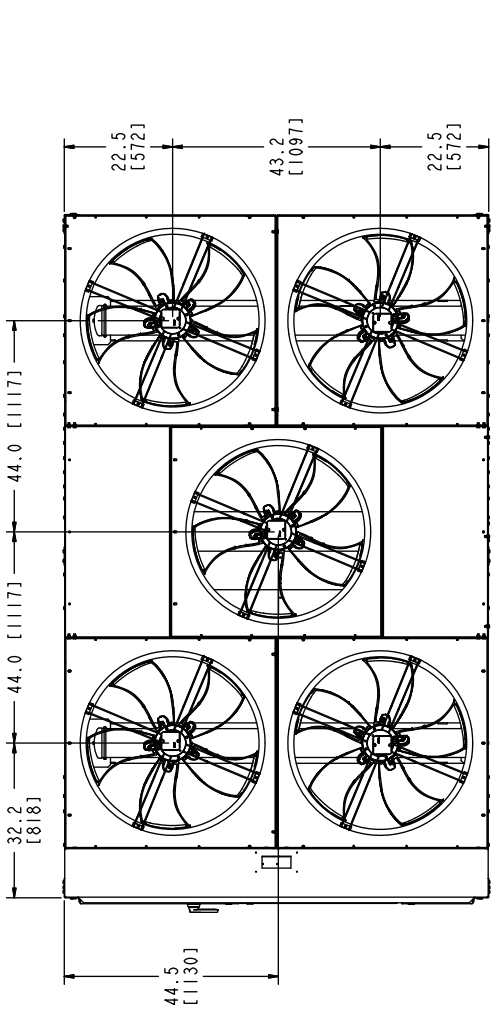

NB1
Distance between
anti vibration
mounts

NB2
Power cable entry
via gland plate

NB3
Control cable
entry

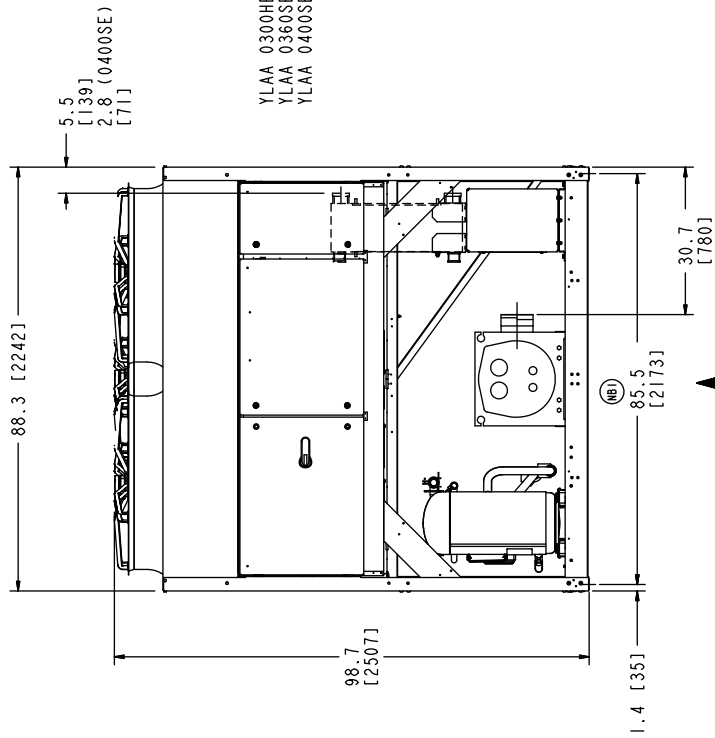

NB4
Chilled water inlet
connection to
evaporator

NB5
Chilled water
outlet connection
to evaporator

NB6
Hot water inlet
connection to
optional heat
recovery
exchanger

NB7
Hot water outlet
connection to
optional heat
recovery
exchanger

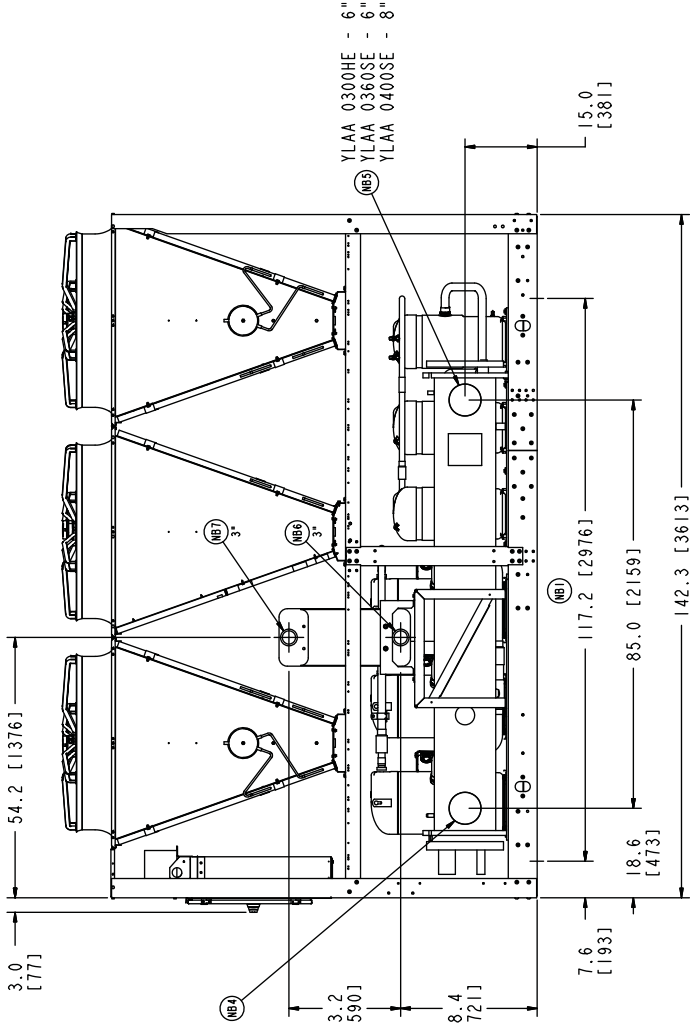

YLAA 0300HE - 6"
YLAA 0360SE - 6"
YLAA 0400SE - 8"

NB4
3"

NB5
3"

NB6
3"

NB7
3"

YLAA 0300HE
YLAA 0360SE
YLAA 0400SE

Dimensions - YLAA0350HE & YLAA0435SE

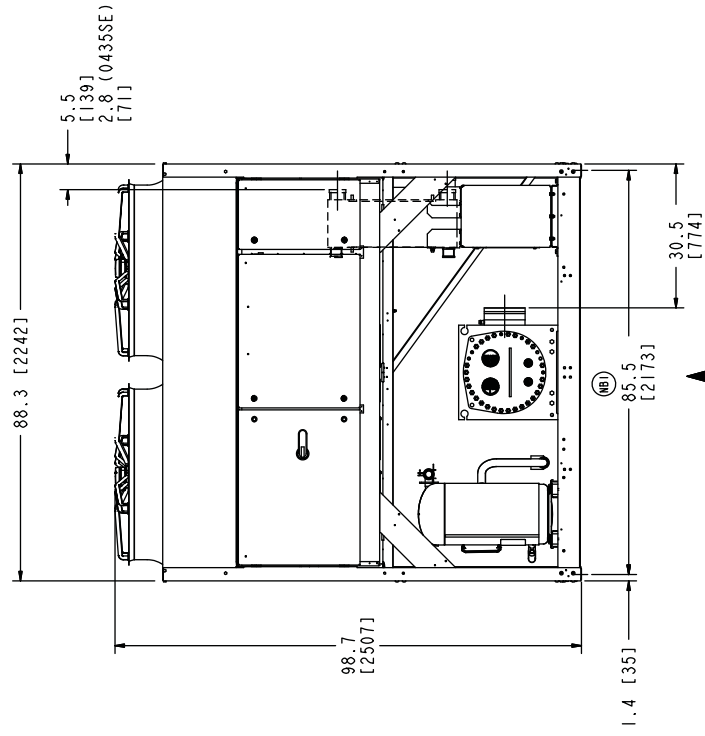
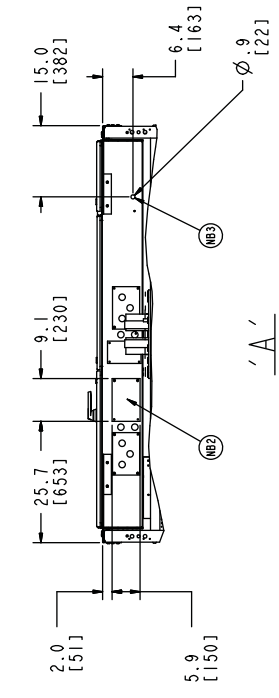
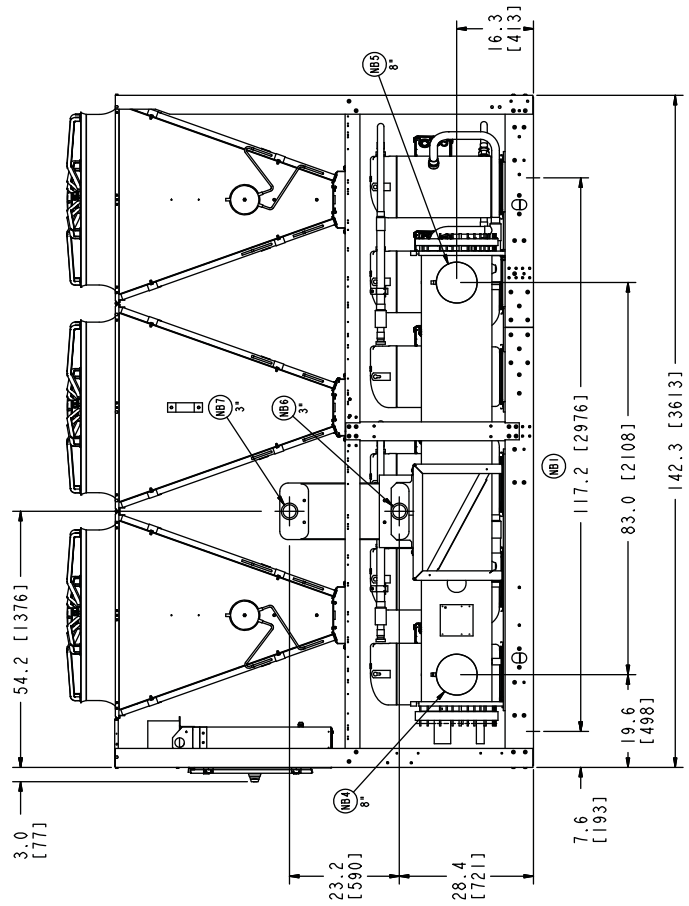
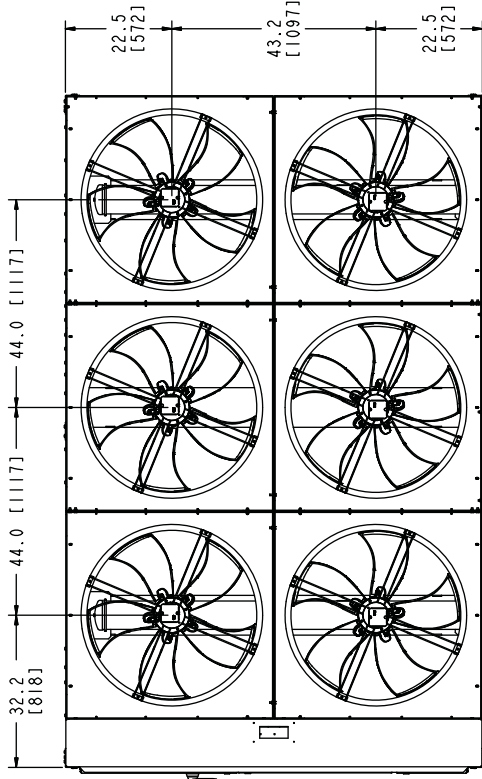

- NB1 Distance between anti vibration mounts
- NB2 Power cable entry via gland plate
- NB3 Control cable entry
- NB4 Chilled water inlet connection to evaporator
- NB5 Chilled water outlet connection to evaporator
- NB6 Hot water inlet connection to optional heat recovery exchanger
- NB7 Hot water outlet connection to optional heat recovery exchanger

YLAA 0350HE
YLAA 0435SE

Dimensions - YLAA0390HE & YLAA0485SE

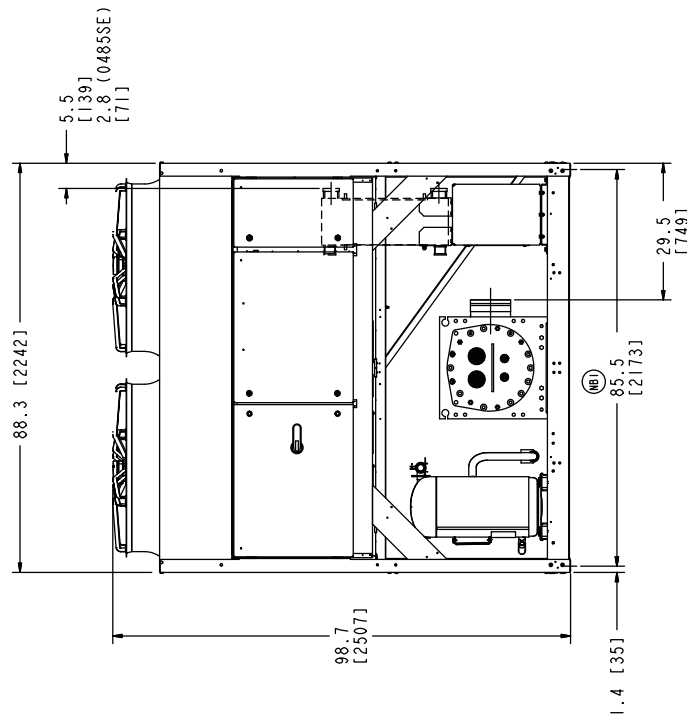
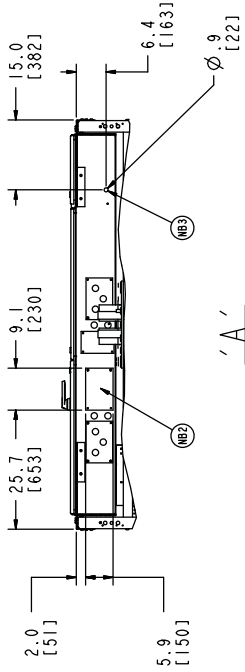
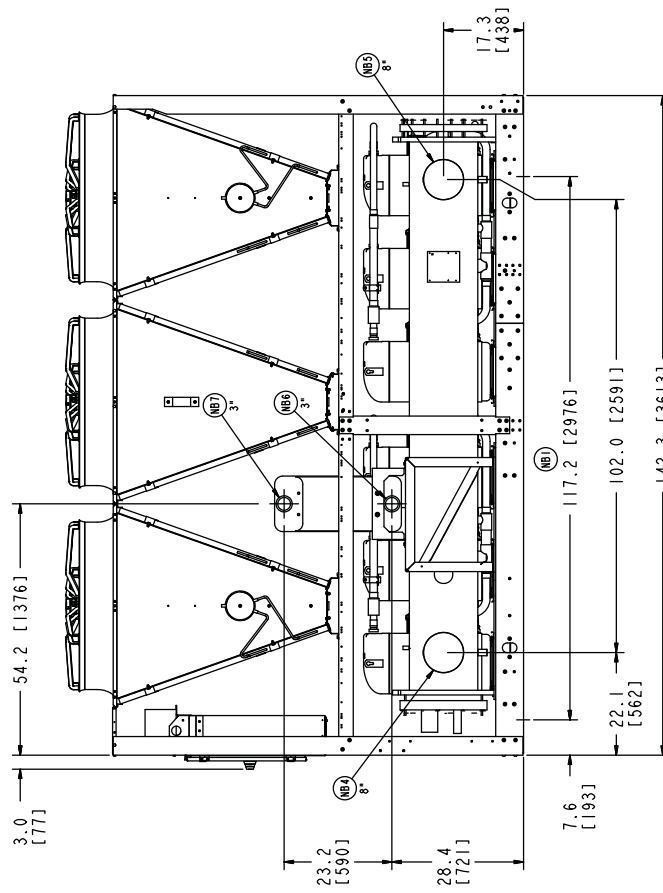
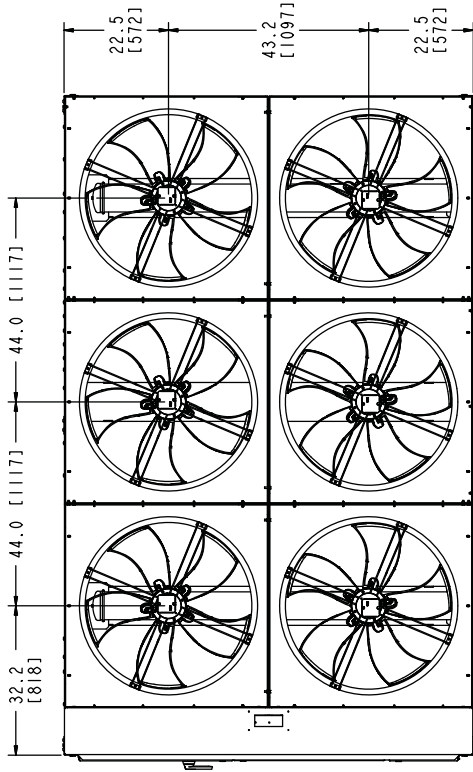

- NB1 Distance between anti vibration mounts
- NB2 Power cable entry via gland plate
- NB3 Control cable entry
- NB4 Chilled water inlet connection to evaporator
- NB5 Chilled water outlet connection to evaporator
- NB6 Hot water inlet connection to optional heat recovery exchanger
- NB7 Hot water outlet connection to optional heat recovery exchanger

YLAA 0390HE
YLAA 0485SE



Dimensions - YLAA0440HE

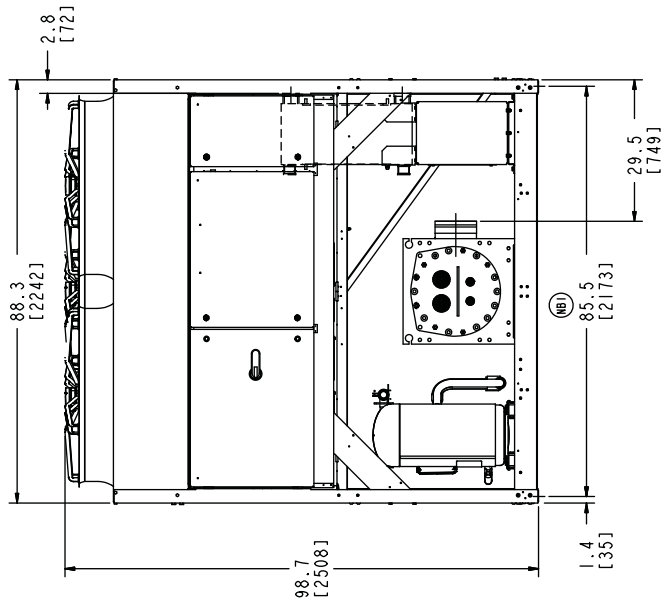
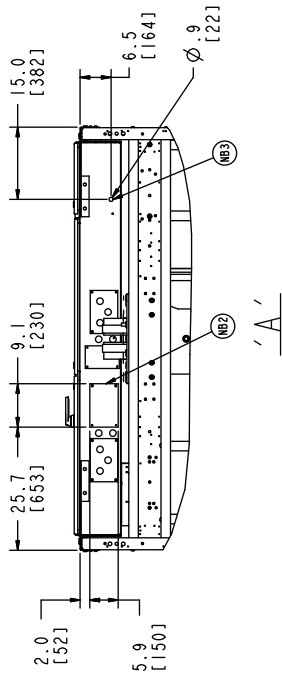
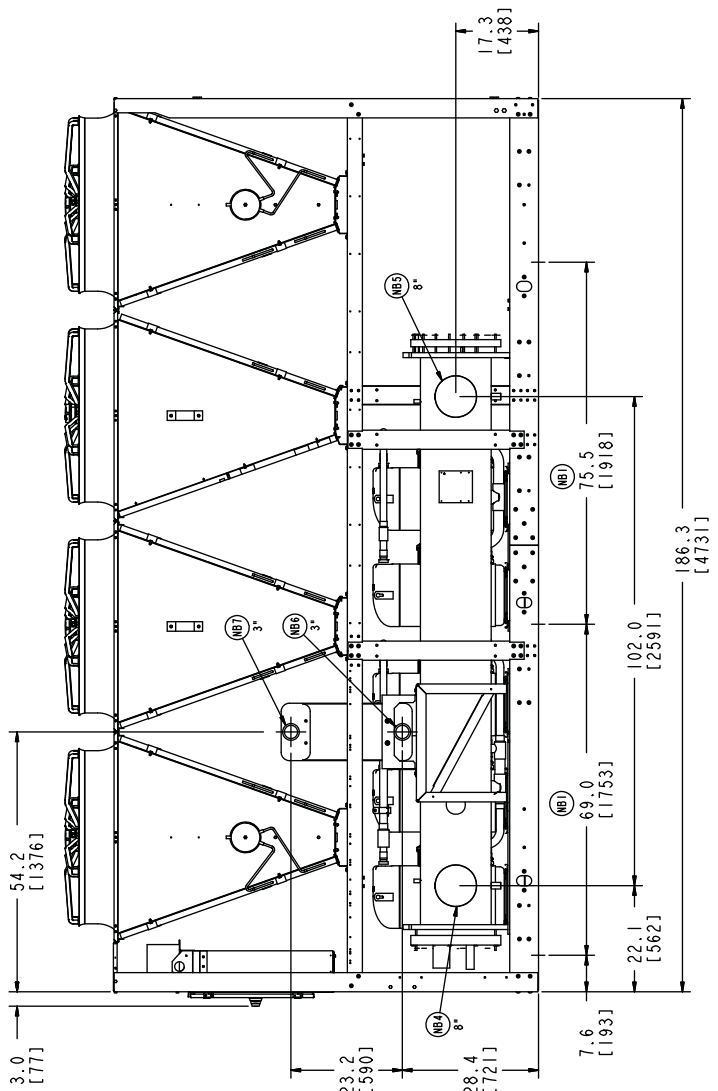
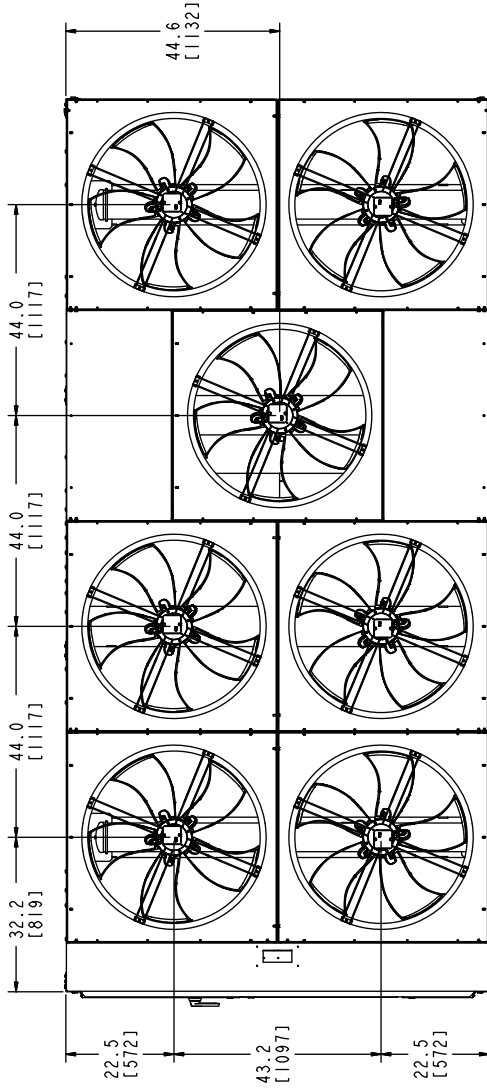

NB1

Distance between anti vibration mounts

NB2

Power cable entry via gland plate

NB3

Control cable entry

NB4

Chilled water inlet connection to evaporator

NB5

Chilled water outlet connection to evaporator

NB6

Hot water inlet connection to optional heat recovery exchanger

NB7

Hot water outlet connection to optional heat recovery exchanger

YLAA 0440HE

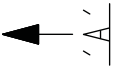

Dimensions - YLAA0455HE

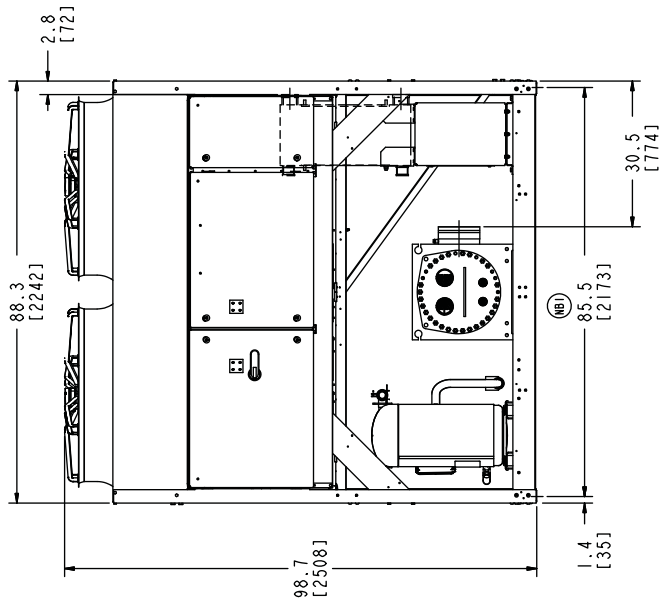
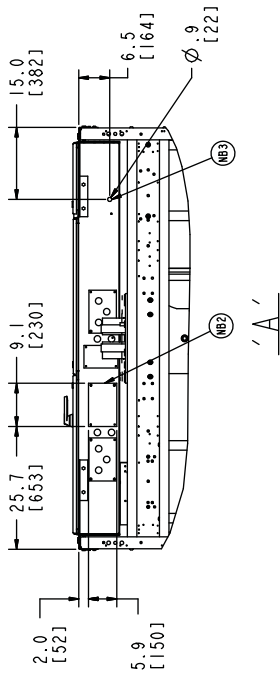
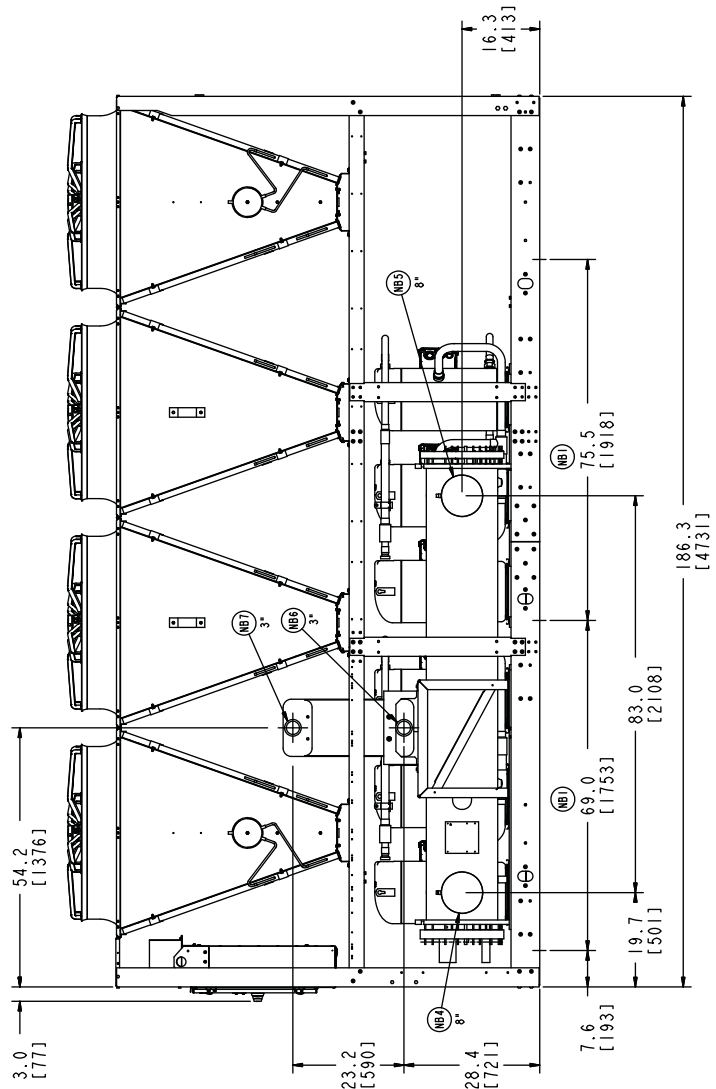
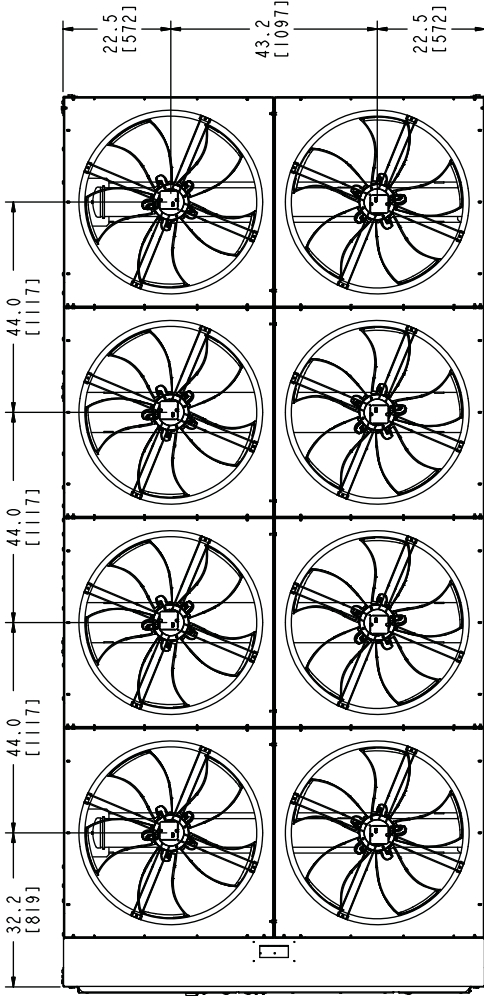

- NB1 Distance between anti vibration mounts
- NB2 Power cable entry via gland plate
- NB3 Control cable entry
- NB4 Chilled water inlet connection to evaporator
- NB5 Chilled water outlet connection to evaporator
- NB6 Hot water inlet connection to optional heat recovery exchanger
- NB7 Hot water outlet connection to optional heat recovery exchanger

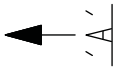

YLAA 0455HE

Dimensions - YLAA0515HE

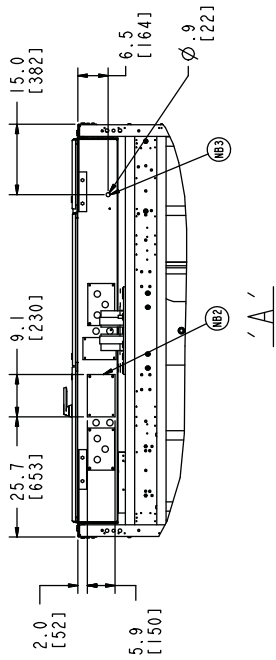
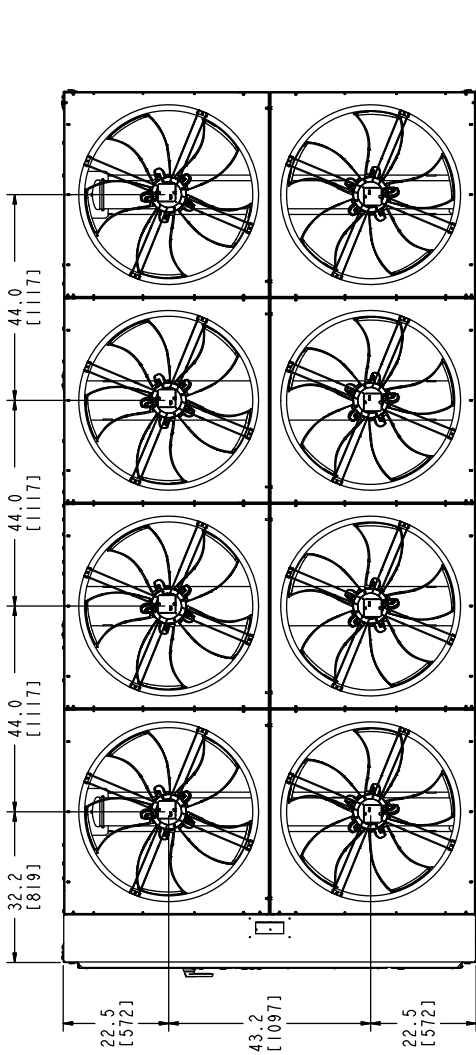

- NB1 Distance between anti vibration mounts
- NB2 Power cable entry via gland plate
- NB3 Control cable entry

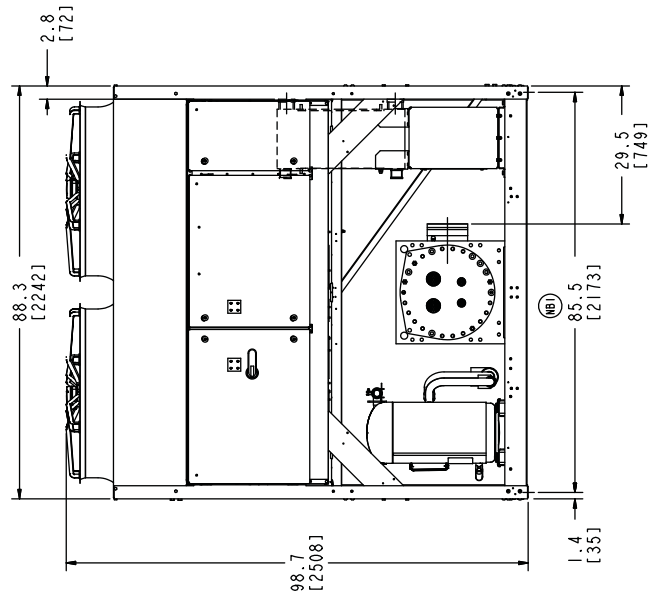
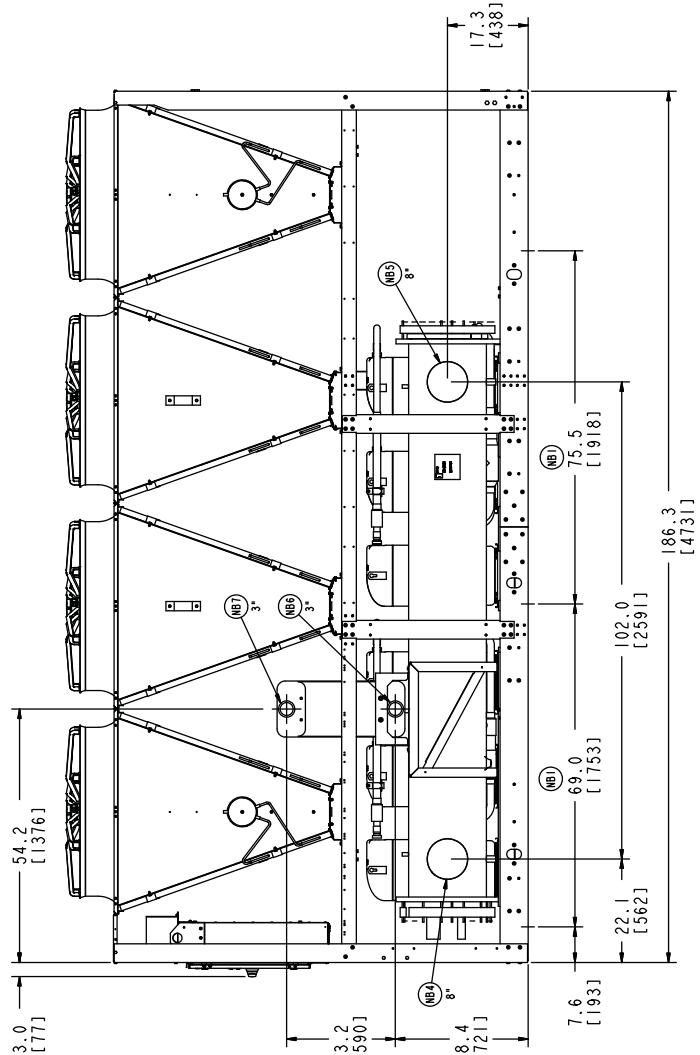

- NB4 Chilled water inlet connection to evaporator
- NB5 Chilled water outlet connection to evaporator
- NB6 Hot water inlet connection to optional heat recovery exchanger
- NB7 Hot water outlet connection to optional heat recovery exchanger

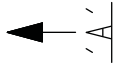

YLAA 0515HE

Notes



www.johnsoncontrols.com